



APT 3500

Smart Pressure Transmitter

For Differential / Gauge / Absolute Pressure Measurement

Instruction Manual

Document Number: IM-APT 3500



APT 3500 Smart Pressure Transmitter

This manual is made so that general user can help to install and operate APT 3500 Smart Pressure Transmitter efficiently.
Before handling APT 3500 transmitter, all users have to be fully aware of it.

Information on this manual can be changed
Without an advance notice.

www.autroltransmitters.com

796 Tek Drive, Crystal Lake, IL 60014, USA
Direct : +1 847-857-6062 | +1 847-779-5000
Fax : +1 847-655-6062
Email : info@autroltransmitters.com

Table of Contents

Chapter 1 Introduction

- 1.1 Using This Manual
- 1.2 Overview of Transmitter
- 1.3 Software Compatibility
- 1.4 Transmitter Components

Chapter 2 Handling Cautions

- 2.1 Unpacking
- 2.2 Models and Specifications Check
- 2.3 Storage
- 2.4 Selecting the Installation Locations
- 2.5 Calibration on Spot after Installation
- 2.6 Pressure Connections
- 2.7 Waterproofing of Cable Conduit Connections
- 2.8 Restrictions on Use of Radio Transceiver
- 2.9 Insulation Resistance Test and Dielectric Strength Test
- 2.10 Installation of Explosion Protected Type Transmitters
- 2.11 EMC Conformity Standards

Chapter 3 Transmitter Functions

- 3.1 Overview
- 3.2 Safety Messages
- 3.3 Warning
- 3.4 Fail Mode Alarm
- 3.5 EEPROM-Write Enable and Disable Mode Switch
- 3.6 Configuration of Alarm and Security Jumper Procedures
- 3.7 Configuration of Zero and Span Procedures
- 3.8 Shop Commissioning using HHT

Chapter 4 Installation

- 4.1 Overview
- 4.2 Safety Messages
- 4.3 Warning
- 4.4 Commissioning on the bench with Hand-Held Terminal
- 4.5 General Considerations
- 4.6 Electrical Considerations (Power Supply)
- 4.7 Wiring
- 4.8 Mechanical Considerations
- 4.9 Environmental considerations

Chapter 5 On-line Operation

- 5.1 Overview
- 5.2 Safety Messages
- 5.3 Configuration Data Review
- 5.4 Check Output
- 5.5 Basic Setup
- 5.6 Detail Setup
- 5.7 Configuration of Information Variable
- 5.8 Configuration of Breakdown Diagnostics Function
- 5.9 Calibration

Chapter 6 Maintenance

- 6.1 Overview
- 6.2 Safety Messages
- 6.3 Hardware Diagnosis
- 6.4 Hardware Maintenance

Appendix I

APT 3500 Smart Pressure
Transmitter LCD Display Code

APPENDIX II

PRODUCT CERTIFICATION

APPENDIX III

Special Condition for Safe use

Chapter 1 Introduction

The APT 3500 Smart Pressure Transmitter is correctly calibrated at the factory before shipment. To ensure correct and efficient use of the instrument, please read this manual thoroughly and fully understand how to operate the instrument before operating it

- ① The contents of this manual are subject to change without prior notice.
- ② All rights reserved. No part of this manual may be reproduced in any form without Autrol's written permission.
- ③ If any question arises or errors are found, or if any information is missing from this manual, please inform the nearest Autrol sales office.
- ④ The specifications covered by this manual are limited to those for the standard type under the specified model number break-down and do not cover custom-made instrument.
- ⑤ Please note that changes in the specifications, construction, or component parts of the instrument may not immediately be reflected in this manual at the time of change, provided that postponement of revisions will not cause difficulty to the user from a functional or performance standpoint.

1-1 Using This Manual

The Chapters in this operating manual provide information on installing, operating, and maintaining devices from the AUTROL Model APT 3500 Smart Pressure Transmitter. The Chapters are organized as follows.

Chapter 2 Handling Cautions

Chapter 2 provides instruction on commissioning and operating Model APT3500 Smart Pressure Transmitters. Informations on software functions, configuration parameters, and on-line variables is also included.

Chapter 3 Transmitter Functions

Chapter 3 contains in consideration of handling Model APT 3500 Smart Pressure Transmitters.

Chapter 4 Installation

Chapter 4 contains mechanical, environment consideration and electrical installation instructions on the Model APT 3500 Smart Pressure Transmitters.

Chapter 5 On-line Operation

Chapter 5 describes the configuration the parameter how to use variety of the Model APT 3500 Smart Pressure Transmitters software function and configuration. See the following list for the details.

- Regulations of circuit's Input/Output characteristics; Sensor or Output Trim
- Changed of output characteristic; Range Configuration, Output Type, Damping, Unit
- Changed of general data; Tag No., Date, Message etc.

Chapter 6 Maintenance

Chapter 6 contains hardware diagnostics ,troubleshooting and maintenance task.

1.2 Overview of Transmitter

Autrol® Smart Pressure Transmitter based in a microprocessor is the pressure transmitter, has a designed capacitance sensor optimized for draft measurement. APT 3500 has a true draft analog range from 4 to 20mA offering that feature that a pressure range or after convert analog range to HART (Communication) digital signal transmit for control systems like DCS, PLC. This Model has explosion protected type and high precision, better reliability and is available on digital communication for the use remotes communication system.

This transmitter is enabled in HART communication with Host, HHT (HART Hand-Held Terminal) or PC Configurator. Thus, transmitter various variables in host is enable to be changed, configured and tested calibrated by users. For the HART Communication between DC Power Supply and Transmitter has to terminate 250~ 550 Ohm.

1.3 Software Compatibility

Autrol® Smart Pressure Transmitter's software is implemented and complemented if necessary. Uses of the transmitter will not be a compatibility software is contained in the host of the HHT(ACONF312 or 275/375/475 HART Communicator). In this case contact us for software DD(Device Descriptor) to be able to use with the transmitter, you must to use loading in HHT, etc.

There may be some differences on supported functions as to Firmware Revision of transmitter. This manual is based on Firmware Revision 10. Function deviations as to firmware Revision are same as under box

Item	Function	Function Supports		Output that is affected by set-up change
		Button	HART	
		Rev.10	(HHT/ SST30)	
Basic Set-up	Range set	●	●	Whole output excluding PV displayed on LCD
	Units set	●	●	PV displayed on LCD
	Damping Second set	●	●	Whole Output
	Transfer Function set	●	●	Whole output excluding PV displayed on LCD
	Low-cut set	●	●	Whole output excluding PV displayed on LCD
	Loop Test	●	●	4~20mA
Calibration	Zero Trim	●	●	Whole Output
	Zero Adjustment	●	●	Whole Output
	Full Trim	x	●	Whole Output
	D/A Trim	x	●	4~20mA

Transmitter Information Set-up	Polling Address set	●	●	4~20mA
	Setting up transmitter basic information (Tag, Date, Descriptor, Message)	x	●	-
LCD Display	LCD mode set	●	●	Whole LCD Display
	Decimal Place set	●	●	Whole LCD Display
	LCD Engineering Mode set (Eng Range, Eng Unit, Eng Transfer Function...)	●	●	LCD Engineering Value
Other	Button Lock set	●	△	-
	Master Reset	●	●	Whole Output

- : Supported.
- x : Not Supported
- △ : Supported but update required

1.4 Transmitter Components

The components and figure of Autrol® Smart Pressure Transmitter is suggested on the next page. Follow the procedure described on figure 1-1, 1-2, 1-3, 1-4, 1-5, 1-6.

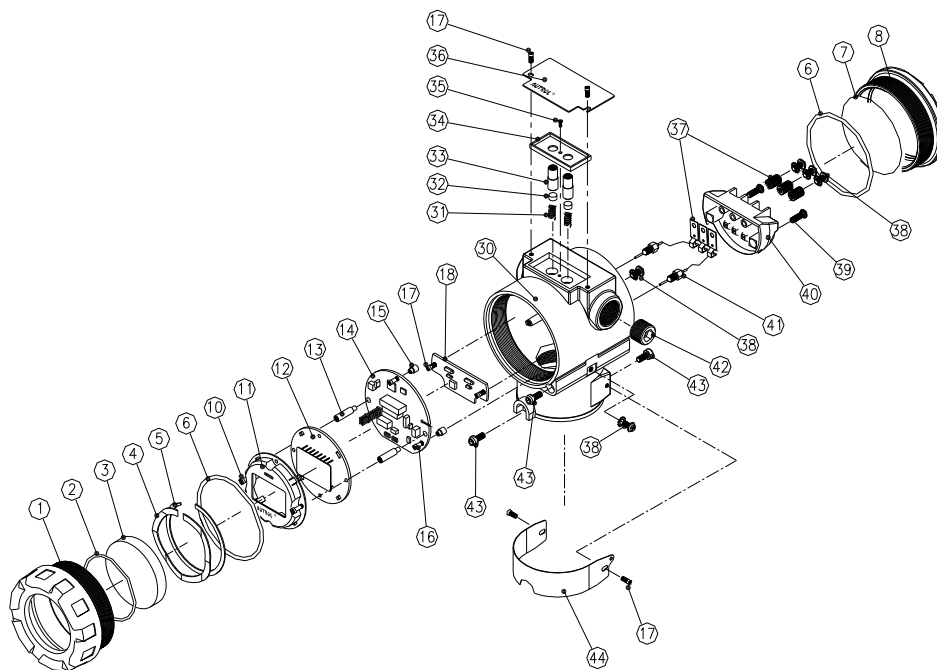

Figure 1-1. Model APT 3500 Transmitter Exposed View (Housing)

P.N	PART NAME	P.N	PART NAME
1	FRONT COVER	18	TERMINAL BOARD
2	O-RING/GLASS	30	HOUSING
3	GLASS	31	SPRING/SWITCH
4	WAVE WASHER	32	MAGNET/SWITCH
5	C-SNAP RING	33	BOTTON/SWITCH
6	O-RING/COVER	34	COVER/SWITCH
7	LABEL	35	SCREW/ SWITCH COVER
8	REAR COVER	36	NAMEPLATE
10	SCREW/LCD	37	COMMUNICATION TEST PIN
11	LCD COVER	38	SCREW/WASHER
12	LCD BOARD	39	SCREW/TERMINAL BLOCK
13	POST/LCD	40	TERMINAL BLOCK
14	MAIN BOARD	41	EMI FILTER
15	POST/MAIN BOARD	42	PIPE PLUG
16	SCREW/MAIN BOARD	43	SCREW
17	SCREW	44	TAGPLATE

Figure 1-2. TRANSMITTER COMPONENTS

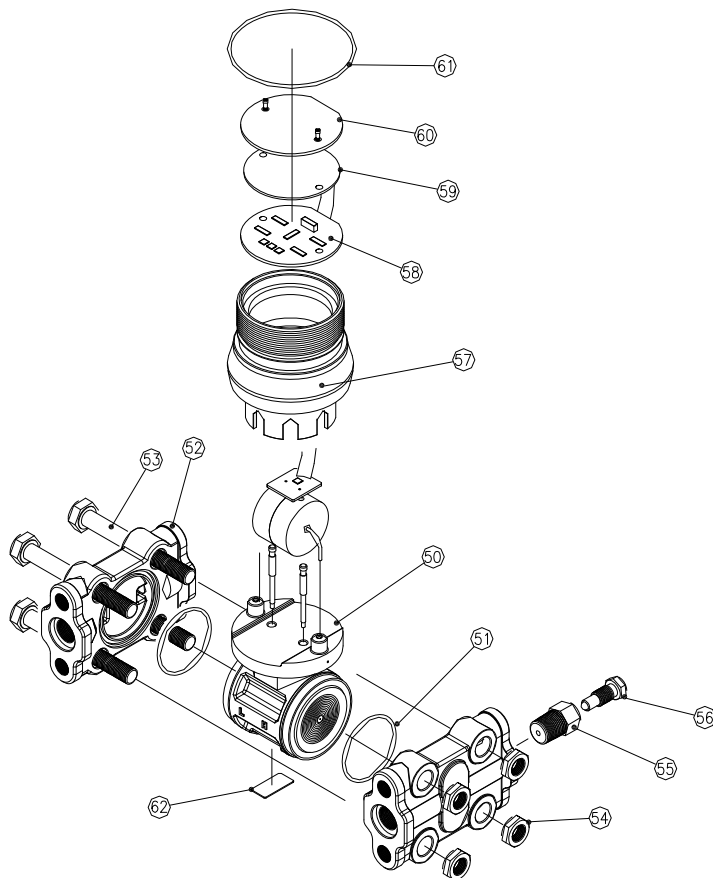

Figure 1-3. Model APT 3500 Exploded View (Sensor Module-D,G,L)

NO.	PART NAME	NO.	PART NAME
50	SENSOR BODY	57	SENSOR BODY ADAPTER
51	O-RING/FLANGE	58	ELECTRONIC ANALOG B/D
52	FLANGE	59	RUBBER PACKING
53	BOLT	60	SHIELD BOARD
54	NUT	61	O-RING/SENSOR BODY
55	DRAIN/VENT BODY	62	LABEL
56	DRAIN/VENT PLUG		

Figure 1-4. TRANSMITTER COMPONENTS

Chapter 2 Handling Cautions

This chapter consists of cautions for transmitter handling and storage, selection of installation locations, insulation and explosion structure, etc.

[Quick Reference Manual]

Step	Job	Job Details	Instrument
1	Unpacking	- Unpack transmitter packing	
2	Model and Specifications Check	- Make sure whether the delivered transmitter is same as options attached on its nameplate	
3	Storage	- Places not exposed to water, non-vibration and non-impact area - Ambient temperature 25 deg C and relative humidity 65% RH	
4	Calibration on a Calibration Room	- Configuration of Range, Zero/Span, Unit, Tag, Damping Time, Transfer Function, DA Trim and other parameters	- HHT - Pressure Source (requested) - Galvanometer
5	Installation Locations	- Where ambient temperature is not fluctuated - Where corrosion happens by chemical materials, etc. - Where vibration and impact is not severe - Where non-explosion area is matched on explosionproof regulations - Where maintenance is very easy	(Engineering)
6	Mechanical Considerations	- Where transmitter can be handled easily - Be cautious not leaking the pressure.	(Engineering)
7	Electrical Considerations	- Connect 24 Vdc (Power Supply is 12 Vdc – 45 Vdc) - For HART communication, total resistance on transmitter terminal loop should be 250 – 550 Ohm.	(Engineering)
8	Mounting and Installation	- For mounting transmitter, an appropriate bracket should be used. - Transmitter should be fixed well against swing.	(Mounting and Installation)
9	Calibration on Spot	- Sensor Zero Trim has to be done after ten seconds, namely, differential pressure become zero and stabilized. - Make sure that PV value of transmitter is zero and current is 4 mA.	HHT or Zero/Span button
10	Pressure	- Do not apply the regulated differential and line pressure. - Close equalizing valve of 3 valve manifold, Then, open stop valve on high and low side slowly and simultaneously.	(Applying pressure)
11	Operation	- Make sure whether transmitter operates well or not	Eye or HHT

2.1 Unpacking

When moving the transmitter to the installation site, keep it in its original packaging. Then, unpack the transmitter there to avoid damage on the way.

2.2 Models and Specifications Check

The model name and specifications are indicated on the nameplate to the case. Please check your specification and wanted model.

2.3 Storage

The following precautions must be observed when storing the instrument, especially for a long period.

- (1) Select a storage area that meets the following conditions:
 - (a) It is not exposed to rain or water.
 - (b) It suffers minimum vibration and shock.
 - (c) If possible, it is preferable at normal temperature and humidity (approx. 25°C, 65% RH).

However, it has an ambient temperature and relative humidity within the following ranges.

- Ambient Temperature: -40 ~ 85°C (without LCD module)
-30 ~ 80°C (with LCD module)

* General Use -20 ~ 60°C (CSA Explosion-proof)

- Relative Humidity: 5% ~ 98% RH (at 40°C)

- * When storing the transmitter, repack it as nearly as possible to the way it was packed when delivered from the factory.
- * If storing a transmitter that has been used, thoroughly clean diaphragm surfaces (the pressure-detector sections) of the diaphragm seals, so that no measured fluid remains on them. In addition, make sure before storing that the pressure-detector and transmitter assemblies are securely mounted.

2.4 Selecting the Installation Locations

The transmitter is designed to withstand severe environmental conditions. However, to ensure stable and accurate operation for many years, the following precautions must be observed when selecting an installation location.

(1) Ambient Temperature

Avoid locations subject to wide temperature variations or a significant temperature gradient. If the location is exposed to radiant heat from plant equipment, provide adequate insulation or ventilation.

(2) Ambient Atmosphere

Avoid installing the transmitter in a corrosive atmosphere. If the transmitter must be installed in a corrosive atmosphere, there must be adequate ventilation as well as measures to prevent intrusion or stagnation of rainwater in conduits. Moreover, there should be appropriate ventilation preventing corrosion by rain gathered on conduit.

(3) Shock and Vibration

Select an installation site suffering minimum shock and vibration (although the transmitter is designed to be relatively resistant to shock and vibration)

(4) Installation of Explosion-protected Transmitters

Explosion-protected transmitters can be installed in hazardous areas according to the gas types for which they are certified.

(5) Select a place that transmitter maintenance is very easy.

2.5 Calibration on Spot after Installation

- (1) Sensor Zero Trim should be done after transmitter is installed on spot, because zero point is not accurate as to mounting status.
- (2) For Sensor Zero Trim, make differential pressure of transmitter for zero in advance. Then, make Sensor Zero Trim after pressure is sufficiently stabilized (after approximately 10 seconds).
- (3) There are two ways for making differential pressure for zero. One is to apply zero differential pressure (making same pressure both high and low side pressure). The other is to close High and Low side of stop valve of 3 valve manifold and to open its equalizing valve.
- (4) Sensor Zero Trimming is to use HHT (ACONF312 or 275/375/475 HART Communicator), PC or PDA Configurator, and to use Zero/Span button. Make sure all details on this manual.
- (5) Refer to On-line Operation for configuring another parameters except Sensor Zero Trim

2.6 Pressure Connections

▲ Warning

- ◆ Instrument installed in the process is under pressure. Never loosen or tighten the flange bolts as it may cause dangerous spouting of process fluid.
- ◆ If the accumulated process fluid may be toxic or otherwise harmful, take appropriate care to avoid contact with the body of inhalation of vapors even after dismounting the instrument from process line for maintenance.

The following precautions must be observed in order to safely operate the transmitter under pressure.

- (1) Never apply a pressure higher than the specified maximum working pressure.
- (2) Confirm the option of pressure connection of transmitter. Necessarily use standardized and quality-approved parts.
- (3) In case of being needed by hard circumstances and regulations, there should be seal equipment for leakage.

2.7 Waterproofing of Cable Conduit Connections

Apply a non-hardening sealant (silicone or tape, etc.) to the threads to waterproof the transmitter cable conduit connections.

2.8 Restrictions on Use of Radio Transceivers

▲ Warning

- ◆ Although the transmitter has been designed to resist high frequency electrical noise, if a radio transeiver is used near the transmitter or its external wiring, the transmitter may be affected by high frequency noise pickup. To test for such effects, bring the transeiver in use slowly from a distance of several meters from the transmitter, and observe the measurement loop for noise effects. Thereafter, always use the transeiver outside the area affected by noise.

2.9 Insulation Resistance Test and Dielectric Strength Test

Since the transmitter has undergone insulation resistance and dielectric strength tests at the factory before shipment, normally these tests are not required. However, if required, observe the following precautions in the test procedures.

(1) Do not perform such tests more frequently than is absolutely necessary. Even test voltages that do not cause visible damage to the insulation may degrade the insulation and reduce safety margins.

(2) Never apply a voltage exceeding 500 Vdc (100 Vdc with an internal lightning protector) for the insulation resistance test, nor a voltage exceeding 500V AC (100V AC with an internal lighting protector) for the dielectric strength test.

(3) Before conducting these tests, disconnect all signal lines from the transmitter terminals. Perform the tests in the following procedure.

(4) Insulation Resistance test

- (a) Short-circuit the + and - SUPPLY terminals in the terminal box.
- (b) Turn OFF the insulation tester. Then connect the insulation tester plus (+) lead wire to the shorted SUPPLY terminals and the minus (-) lead wire to the grounding terminal.
- (c) Turn ON the insulation tester power and measure the insulation resistance. The voltage should be applied short as possible to verify that insulation resistance is at least 20M Ω .
- (d) After completing the test and being very careful not to touch exposed conductors disconnect the insulation tester and connect a 100k Ω resistor between the grounding terminal and the short-circuiting SUPPLY terminals. Leave this resistor connected at least three second to discharge any static potential. Do not touch the terminal while it is discharging.

(5) Dielectric Strength Test

- (a) Short-circuit the + and - SUPPLY terminals in the terminal box.
- (b) Turn OFF the dielectric strength tester. Then connect the tester between the shorted SUPPLY terminal and the grounding terminal. Be sure to connect the grounding lead of the dielectric strength tester to the ground terminal.

(c) Set the current limit on the dielectric strength tester to 10mA, then turn ON the power and gradually increase the tester voltage from '0' to the specified voltage.

(d) When the specified voltage is reached, hold it for one minute.

(e) After completing this test, slowly decrease the voltage to avoid any voltage surges.

2.10 Installation of Explosion Protected Type Transmitters

2.10.1 KOSHA Certification

Caution for KOSHA Flameproof is following type.

[Note1] Model APT 3500 diaphragm sealed for potentially explosive atmosphere:

- Type of Protection and Marking Code: Ex d II C T6
- Temperature Class: T6
- Ambient Temperature: -20 ~ 60°C
- Process Temperature: Max. 80°C

[Note2] Electrical Data

- Supply Voltage: Maximum 45 Vdc
- Output signal: 4 ~ 20mA, maximum 22mA

[Note3] Installation

- All wiring shall comply with local installation requirement.
- The cable entry devices shall be of a certified flameproof type, suitable for conditions of use.

[Note4] Operation

- Wait one minute after power -disconnection, before opening the enclosure.
- Take care not to generate mechanical spark when access to the instrument and peripheral devices in hazardous location.

[Note5] Maintenance and Repair

- The instrument modification or parts replacement by other than authorized representative of Autrol is prohibited and will void KOSHA Flameproof.

2.11 EMC Conformity Standards

EMC Standard : IEC 61000-4 series

Autrol recommends customer to apply the Metal Conduit Wiring or to use the twisted pair Shield Cable for signal wiring to conform the requirement of EMC Regulation, when customer installs AUTROL Series Transmitters to the plant.

Chapter 3 Transmitter Functions

3.1 Overview

This Chapter contains information on operating Model APT 3500. Tasks that should be performed on the bench priori to installation are explained in this chapter.

3.2 Safety Message

Procedures and instructions in this chapter may require special precautions to ensure the safety of the personal performing the operations. Information that raises potential safety issues is indicated by warning symbol(▲). Refer to the following safety messages before performing an operation preceded by this symbol.

3.3 Warning

▲ Warning
<p>Explosion can result in death or serious injury:</p> <ul style="list-style-type: none"> ◆ Do not remove the transmitter covers in explosion environments when the circuit is alive. ◆ Transmitter covers must be fully engaged to meet explosionproof requirements.

▲ Warning
<p>Electrical can result in death serious injury:</p> <ul style="list-style-type: none"> ◆ The qualification which is educated only the person whom it prepares will be able to establish the transmitter.

▲ Warning
<p>Electrical can result in death serious injury:</p> <ul style="list-style-type: none"> ◆ Avoid contact with the leads and terminals. High voltage that may be present on leads can cause electrical shock.

3-4. Fail Mode Alarm

AUTROL® Smart Pressure Transmitter automatically and continuously performs self-diagnostic routines. If the self-diagnostic routines detect a failure, the transmitter drives its output outside of the normal saturation values. The transmitter will drive its output low(down) or high(up) based on the position of the failure mode alarm jumper . See Table 3.1 for Output values.

[Table 3-1 Standard Alarm and Saturation Value]

Level	4~20mA Saturation	4~20mA Alarm
Low/Down	3.9 mA	≤ 3.78 mA
High/Up	20.8 mA	≥ 21.1 mA

Fail Mode Select Jumper Switch has in LCD Module and Main CPU Module and Jumper Switch Line is connected circuital. In case of Not LCD Module, we can use CPU Module's Fail Mode Select Jumper Switch and In case of LCD Module we can use LCD Module's Jumper Switch. In this case, CPU Module is selected "Down" side. No selected we can select "Down" side. (Jumper Select Switch is followed in Figure 3-2, 3-3)

Select Fail Mode	Both LCD Module and CPU Module		Only CPU Module
	CPU Module	LCD Module	CPU Module
Fail Down	Down	D	D
Fail Up	Down	U	U
	Up	U or D	

< Fail Mode Selection DIP Switch of CPU Module >

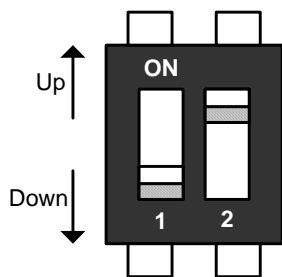

- 1. WR_EN (EEPROM Write Enable)
DOWN : Enable
UP : Protected
- 2. Fail Mode Alarm
DOWN : Low
UP : High

3-5. EEPROM-Write Enable / Disable Mode Switch

There is the EEPROM (Electrically Erasable Programmable ROM) restoring various configuration variables in Transmitter. For protect to change configuration variable data in software, hardware side there is Write-Protect Mode and Jumper Switch selected it segmented "EEP-Write DIS / EN " in Main CPU Module. Thus if you connect Jumper to DIS you can't change configuration data in EEPROM, when you connect Jumper to EN you can change configuration data in EEPROM. No connected Jumper, it is classified EN. At the factory before shipment, it is configured "EN". (Following figure 3-3)

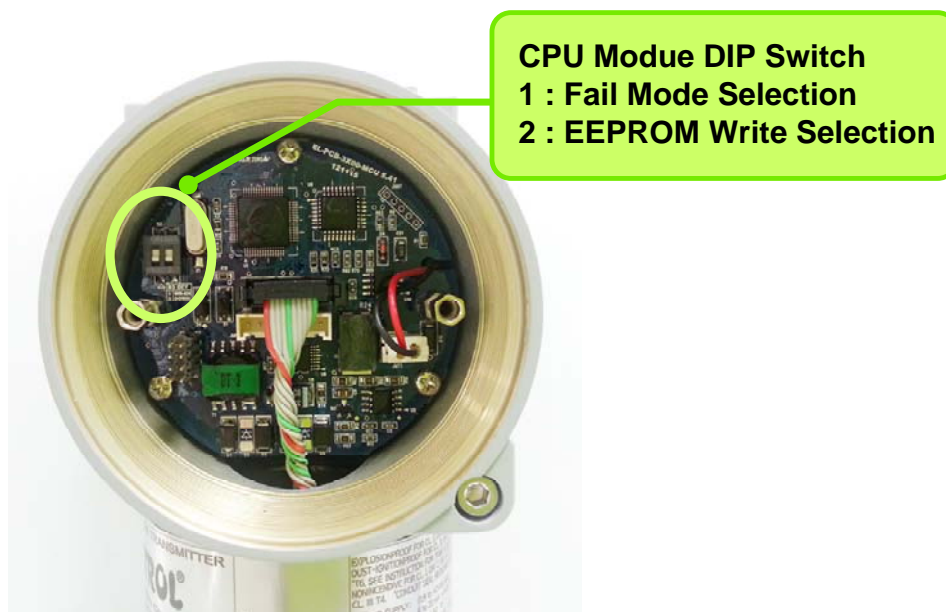

Figure 3-3. CPU Module Fail Mode, EEPROM-Write Selection Jumper Switch

There are two security methods in APT 3500. Following this.

- (1) Security Jumper: protect to writing configuration parameters of transmitter.
- (2) Physical removing Zero and Span Magnetic Buttons of Transmitter: you are not able to regulate Zero and Span in Local.

[Notification] If EEP-Write is not connected, it is classified Security Off state.

3.5.1 Security Jumper (EEPROM Write Protect)

Protect to change Configuration Parameter of transmitter to Write Protect Jumper.

3.5.2 Zero and Span Magnetic Button

To remove Magnetic Button, you can't configure Zero and Span in Local.

3.6 Configuration of Alarm and Security Jumper Procedures

To change Jumper's position, follow this.

- (1) If install the transmitter, cutoff power.
- (2) Open the housing front side covers. In case Power Supply, don't open the covers of transmitter
- (3) After turn off Jumper, turn on at wanted position.
- (4) Close the housing covers. You must fully engage to meet explosion proof requirements

3.7 Configuration of Zero and Span Procedures

This product is designed to enable basic set-up only by Transmitter own buttons without additional devices. Because progression of button manipulation is displayed on LCD, button manipulation can be used only in products containing LCD module. Opening the Name Plate cover in the housing top, you can see ZERO and SPAN buttons. This product uses contact-less magnetic buttons, which are completely separated from the Transmitter interior. Hence, this is suitable for the case, such as flameproof environment, that Transmitter interior should be sealed.



[Figure 3-4 Transmitter's Zero/Span configuration Button]

[Note1] ZERO and SPAN button are designed to be active by finger push but, depending on use environment, tools such as pen or screw driver should be used to push deep for accurate action.

[Note2] If magnetic screw driver is used, button may not be active. Hence, non-magnetic screw

driver should definitely be used.

To provide various set-up functions with 2 buttons, ZERO and SPAN, this product allows menu control in the Tree method.

Using functions which supported by buttons,

(1) Zero/Span Button mounted in Transmitter.

(2) HHT Configurator by HART Communication (following chapter 4)

** Refer to "275 Hart Communicator User Guide" on Appendix II for details.

Zero/Span configuration process by Zero/Span Button of transmitter is following this.

(1) Release to both sides bolts of Name Plate in the upper part of transmitter and if push down right of Name Plate, appear to Zero/Span Button (following figure 3-4)

(2) Zero Configurations

Set the current process value for Lower Range Value (4 mA).

Put purposed pressure for zero over 10 seconds and push Zero Button over 5 seconds. Then show "Zero" in LCD window. After checking this message, take off the finger from the button. Push the button over 3 seconds after 1 second passes. Then show "-ZE-" in LCD window. By this message, all zero configurations have finished. If the works has failed, show "SPeR" or "SEtE" in LCD window.

(3) Span Configurations

Set the current process value for Upper Range Value (20 mA).

Put purposed pressure for zero over 10 seconds and push Span Button over 5 seconds. Then show "SPAN" in LCD window. After checking this message, take off the finger from the button. Push the button over 3 seconds after 1 second passes. Then show "-SP-" in LCD window. By this message, all zero configurations have finished. If the works has failed, show "SPeR" or "SEtE" in LCD window.

Please refer to Appendix 1 for the button error and LCD display message

The other functions which supported by ZERO / SPAN Buttons are available as below.

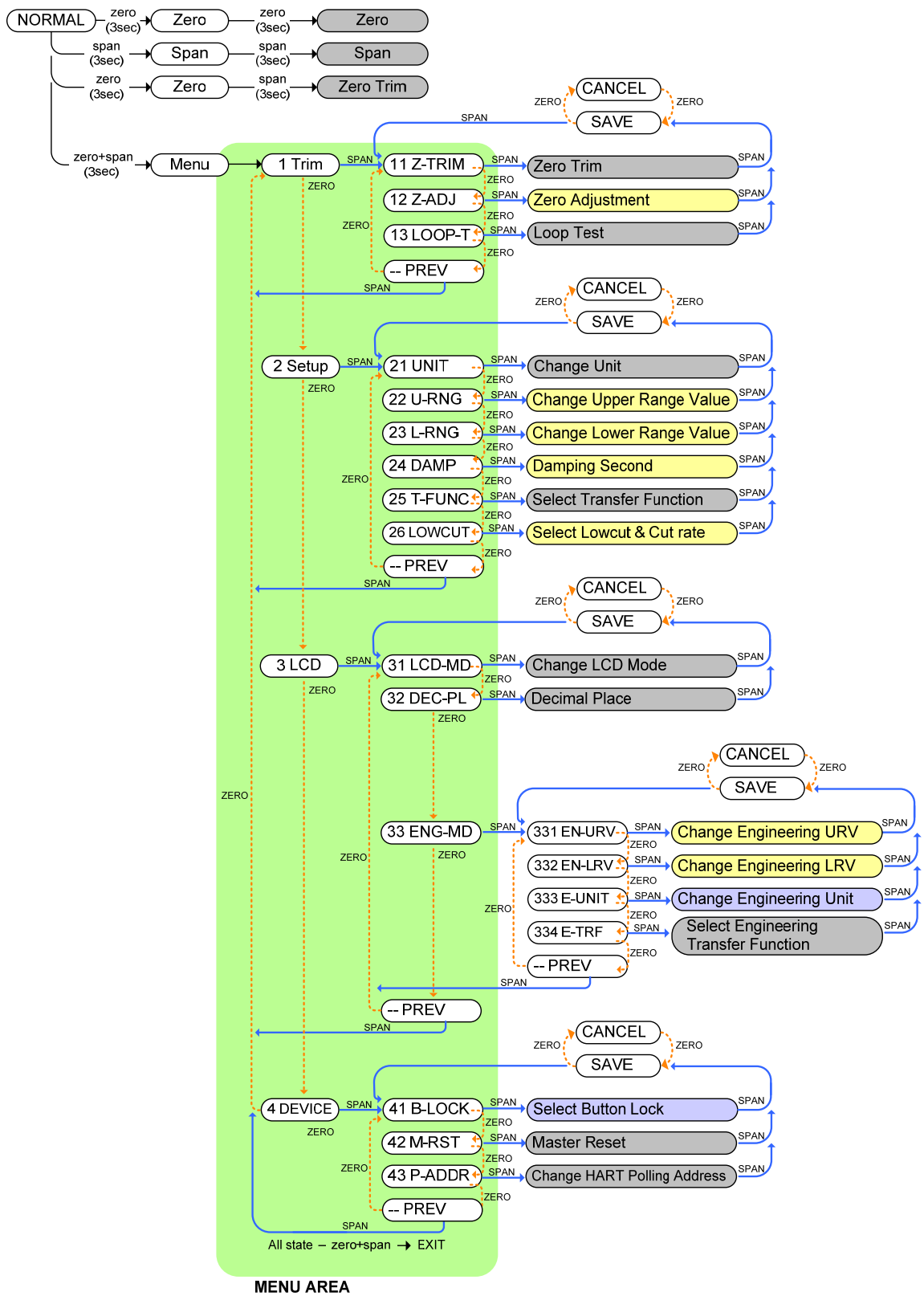

[Menu Tree of ZERO+SPAN Button Function]

- (1) Moving within menu: Zero
- (2) Enter or moving to sub menu: Span
- (3) Button manipulation ending or DIGIT movement: ZERO + SPAN (simultaneous push of ZERO and SPAN)
- (4) Button input time: - 3 seconds in Normal mode
- Instant after entering menu

In the normal operation mode, if you push ZERO+SPAN button for 3 seconds, LCD displays "Menu" and, if you release button, LCD displays the initial item "1 Trim" and you enter the menu Tree.

After that, button may be pushed shortly for input. In the menu Tree, you can push ZERO button to move to the next item and push SPAN button to execute the indicated item or to move to low level menu. If you choose "-- PREV" out of the menu items and push SPAN button, you go to high level menu.

After entering the menu Tree, if the currently chosen item is within the MENU AREA in the above Figure, ZERO+SPAN input terminates button manipulation and returns you to the normal mode. In the menu Tree, if ZERO and SPAN button is pushed long the pushed button is input repeatedly.

After completing choice and input of each function, choose "SAVE" and "CANCEL" to confirm the result of application. "SAVE" and "CANCEL" are converted each time ZERO button is pushed, and if you choose "SAVE" and, then, push SPAN input is applied, and if you choose "CANCEL" and, then, push SPAN the present input is cancelled.

Caution: After about 30 seconds without any action, the button function will be finished.

- How to input numerical value

Function needs to put numerical value: Functions of **12 Zero Adjustment, 22 Change Upper Range Value, 23 Change Lower Range Value, 24 Damping Second** require numerical input.

Numerical input method: Once numerical input starts, the highest input DIGIT flickers. Then, if you push ZERO number increases while if you push SPAN number decreases. If you push ZERO+SPAN after changing to the desired number, the next DIGIT flickers and you can use

ZERO and SPAN button to change value in the same method.

After repeating the above procedure and changing value to the last DIGIT, push ZERO+SPAN to complete numerical input, and make the final check of the entered value. While LCD displays "SAVE", push SPAN button to apply the entered value and complete numerical input procedure. If you push ZERO button while LCD displays "SAVE", "CANCEL" is displayed. Then, if you push SPAN button the entered value is cancelled.

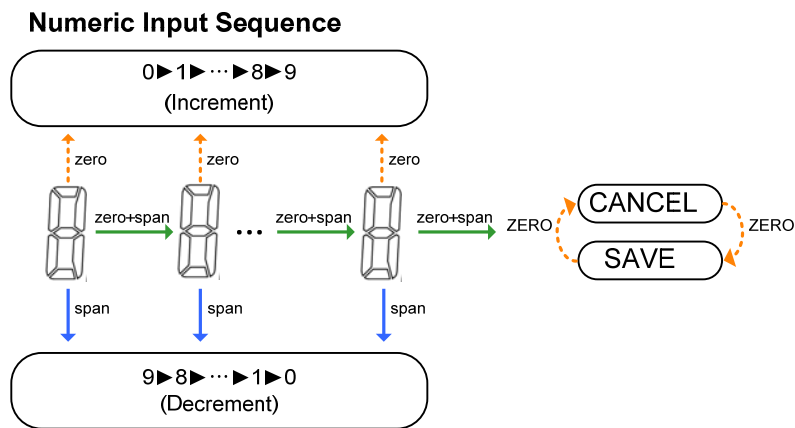

- How to input character value

Function needs to put character value: Functions of **333 Change Engineering Unit, 41 Select Button Lock** require latter input.

Letter input method is the same as numerical input method except that not only number but also letter and partly special character can be enter into each DIGIT.

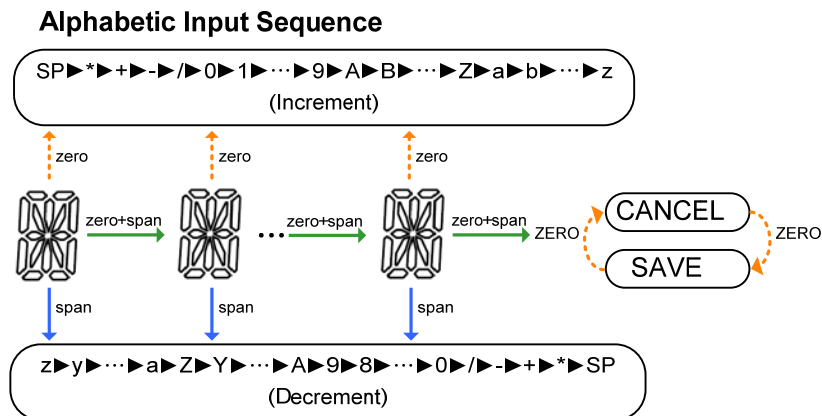

• Exercises for each function

- ZERO TRIM
 - Executing the menu to put ZERO+SPAN button.
 - Moving to the sub directory to put Span button when 1 TRIM message appear.
 - Executing Zero Trim Function to put the Span button when 11 Z-TRIM message appear.
 - If "SAVE" is displayed, push SPAN Button to save set-up value.

- Zero Adjustment : To change the PV value as 14
 - Executing the menu to put ZERO+SPAN button.
 - Moving to the sub directory to put Span button when 1 TRIM message appear.
 - Moving to next menu to put Zero button when 11 Z-TRIM message appear.
 - Executing Zero Adjustment function to put Span button when 12 Z-ADJ message appear.
 - LCD displays '0.0' and the highest input DIGIT flickers.
 - If the flickering DIGIT is not tens place, push ZERO+SPAN button until tens place flickers.
 - When tens place flickers, push ZERO button once to change the LCD display value to "10.0". Then, push ZERO+SPAN button.
 - When units place flickers, push ZERO button 4 times to change the LCD display value to "14.0". Then, until "SAVE" is displayed, push ZERO+SPAN button repeatedly.
 - If "SAVE" is displayed, push SPAN Button to save set-up value.

- Loop Test : Fix the 4~20mA Loop Current output to a certain value.
 - Executing the menu to put ZERO+SPAN button.
 - Moving to the sub directory to put Span button when 1 TRIM message appear.
 - Moving to next menu to put Zero button when 11 Z-TRIM message appear.
 - Moving to next menu to put Zero button when 12 Z-ADJ message appear.
 - Executing Loop Test function to put Span button when 13 LOOP-T message appear.
 - If Loop Test Function is performed, usable modes are indicated in the 2nd line of LCD, and indication contents are as follows:

Indication Content	Explanation
OFF	The current that corresponds to PV measured without using Loop Test function is sent out

mA-HDL	The present current is fixed and sent out
4mA, 8mA, 12mA, 16mA 20mA	Each chosen current is fixed and sent out
OTHER	The current value user entered as input is fixed and sent out. After choosing OTHER, push SPAN button. Then, a value is entered and current is fixed to that value.

-Every time ZERO Button is pushed, Mode is changed, and after choosing the desired mode, use SPAN Button to choose set-up value.

- If "SAVE" is displayed, push SPAN Button to save set-up value.
- Once current is fixed, it is kept fixed regardless of changes to measured value and parameters, and repeat the above procedure to turn off function or keep the function until the power is turned off and on. Also, if current is fixed using Loop Test function, the present current is maintained along with "Loop" message on LCD.

- Change Unit

- Executing the menu to put Zero+Span button.
- Moving to next menu to put Zero button when 1 TRIM message appear.
- Moving to sub directory to put Span button when 2 SETUP message appear.
- Executing the Change Unit function to put Span button when 21 UNIT message appear.
- Until the desired Unit is displayed in the LCD lower part, push ZERO button repeatedly.
- If the desired Unit is displayed, push SPAN button to complete set-up.
- If "SAVE" is displayed, push SPAN Button to save set-up value.

- Change Upper Range Value

- Executing the menu to put Zero+Span button.
- Moving to the next menu to put Zero button when 1 TRIM message appear.
- Moving to the sub directory to put Span button when 2 Setup message appear.
- Moving to the next menu to put Zero button when 21 Unit message appear.
- Executing the function to put Span button when 22 U-RNG message appear.
- The procedure of setting value is same as Zero Adjustment.

- Change Lower Range Value

- Executing the menu to put Zero+Span button.
- Moving to the next menu to put Zero button when 1 TRIM message appear.

- Moving to the sub directory to put Span button when 2 Setup message appear.
 - Moving to the next menu to put Zero button when 21 Unit message appear.
 - Moving to the next menu to put Zero button when 22 U-RNG message appear.
 - Executing the function to put Span button when 23 L-RNG message appear.
 - The procedure of setting value is same as Zero Adjustment.
- Change Damping Second
- Executing the menu to put Zero+Span button.
 - Moving to the next menu to put Zero button when 1 TRIM message appear.
 - Moving to the sub directory to put Span button when 2 Setup message appear.
 - Moving to the next menu to put Zero button when 21 Unit message appear.
 - Moving to the next menu to put Zero button when 22 U-RNG message appear.
 - Moving to the next menu to put Zero button when 23 L-RNG message appear.
 - Executing the function to put Span button when 24 DAMP message appear.
 - The procedure of setting value is same as Zero Adjustment.
- Select Transfer Function : Choose Transfer Function for the 4~20mA output.
- Executing the menu to put Zero+Span button.
 - Moving to the next menu to put Zero button when 1 TRIM message appear.
 - Moving to the sub directory to put Span button when 2 Setup message appear.
 - Moving to the next menu to put Zero button when 21 Unit message appear.
 - Moving to the next menu to put Zero button when 22 U-RNG message appear.
 - Moving to the next menu to put Zero button when 23 L-RNG message appear.
 - Moving to the next menu to put Zero button when 24 DAMP message appear.
 - Executing the function to put Span button when 25 T-FUNC message appear.
 - Until the desired Transfer Function, either "LINEAR" or "SQRT", is displayed on the LCD lower part, push ZERO button repeatedly.
 - If the desired Transfer Function is displayed, push SPAN Button to complete set-up.
 - If "SAVE" is displayed, push SPAN Button to save set-up value.
- Select Low cut & Cut rate : Set up Low cut and Cut rate that will be used when the SQRT Transfer Function is chosen.
- Executing the menu to put Zero+Span button.
 - Moving to the next menu to put Zero button when 1 TRIM message appear.
 - Moving to the sub directory to put Span button when 2 Setup message appear.
 - Moving to the next menu to put Zero button when 21 Unit message appear.

- Moving to the next menu to put Zero button when 22 U-RNG message appear.
- Moving to the next menu to put Zero button when 23 L-RNG message appear.
- Moving to the next menu to put Zero button when 24 DAMP message appear.
- Moving to the next menu to put Zero button when 25 T-FUNC message appear.
- Executing the function to put Span button when 26 LOWCUT message appear.
- Every time ZERO button is pushed, the LCD lower part displays "LINEAR", "ZERO", and "C-RATE" in the order. If SPAN button is pushed after choosing "LINEAR" and "ZERO", Low cut mode is set up as Linear and Zero, respectively. If SPAN button is pushed after choosing "C-RATE", a number is entered and set up as Cut rate.
- If "SAVE" is displayed, push SPAN Button to save set-up value.

* If SQRT Transfer Function is chosen, output changes severely even by a small change to input in the region of low pressure. Because this may cause distortion to input analysis, a technique of applying non-SQRT Transfer Function is used when pressure is lower than a certain value. This product supports this function by setting up Low cut mode.

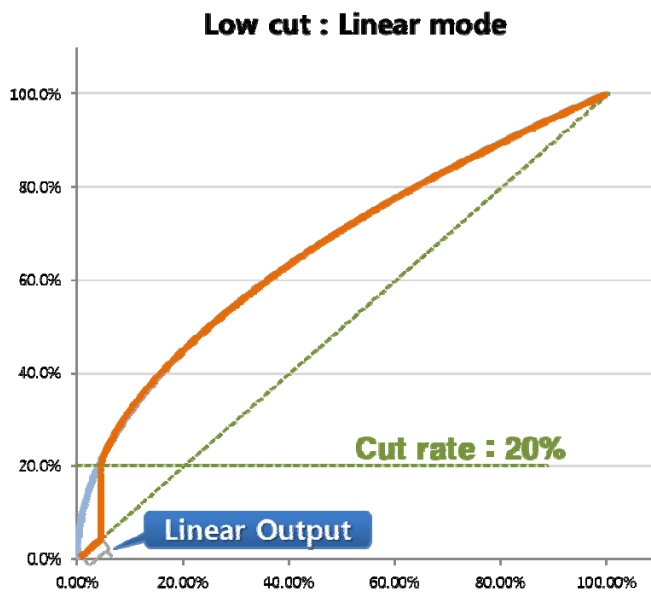

When Lowcut is set up as Linear mode, apply linear Transfer Function if pressure is lower than Cut rate.

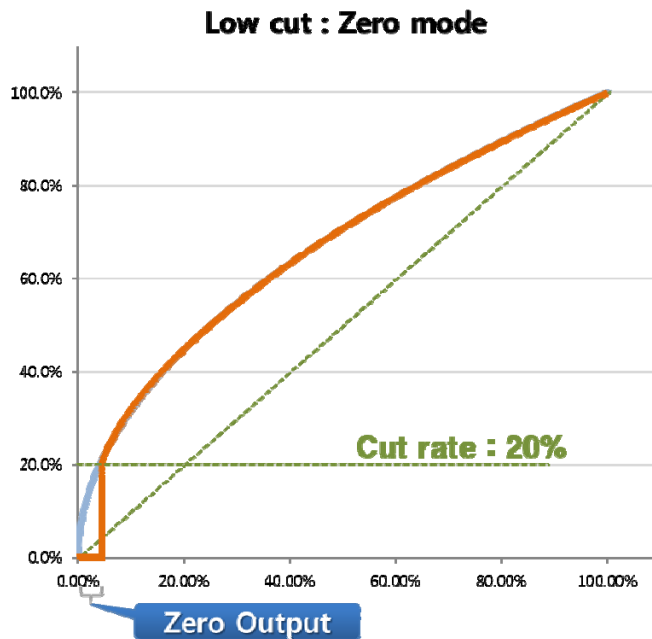

When Low cut is set up as Zero mode, Zero is printed out if pressure is lower than Cut rate.

Figure 3–9. Low cut mode comparison

- Change LCD Mode
 - Executing the menu to put Zero+Span button.
 - Moving to the next menu to put Zero button when 1 TRIM message appear.
 - Moving to the next menu to put Zero button when 2 Setup message appear.
 - Moving to the sub directory to put Span button when 3 LCD message appear.
 - Executing the function to put Span button when 31 LCD-MD message appear.
 - If LCD Mode set-up Function is performed, usable LCD modes are indicated in the 2nd line of LCD, and indication contents are as follows:

Indication Content	Explanation
NOR_RO	Normal Rotation Mode. PV, %, mA are indicated alternately.
NOR_PV	PV Mode. Only measured PV is indicated.
NOR_%	Percent Mode. Measured PV is indicated in Percent with respect to Range.
NOR_mA	mA Mode. 4~20mA current values are indicated for measured PV.
ENG_RO	Engineering Rotation Mode. Engineering PV, %, mA are indicated alternately.

ENG_PV	Engineering PV Mode. Converted PV is indicated in the set-up Engineering Range.
--------	---

- Whenever ZERO Button is pushed, LCD Mode is changed, and after choosing the desired mode, use SPAN Button to save set-up values.

- Decimal Place : Set up decimal place of the numerical value displayed on LCD.
 - Executing the menu to put Zero+Span button.
 - Moving to the next menu to put Zero button when 1 TRIM message appear.
 - Moving to the next menu to put Zero button when 2 Setup message appear.
 - Moving to the sub directory to put Span button when 3 LCD message appear.
 - Moving to the next menu to put Zero button when 31 LCD-MD message appear.
 - Executing the function to put Span button when 32 DEC-PL message appear.
 - When Decimal Place function excuted, the type of decimal place will be appear on the secondline of LCD as below.

Display	Explanation	Max. Value
AUTO	Target value will be displayed automatically (Former Display Type)	9999
5-0	None decimal place	9999
4-1	Display one decimal place	9999.9
3-2	Display two decimal place	999.99
2-3	Display three decimal place	99.999
1-4	Display four decimal place	9.9999

- Firstly, 0.0 will be display on the first line of LCD.
- Decimal place will be change whenever put the Zero button. Saving the setting value to put Span button after select the required decimal palce.
- The set value will be applicable for displaying PV value and Engineering value. 3-2 format will be displayed for mA and % regardless any setting.
- LCD_OV message and current setting Unit will be displayed when over the LCD limitvalue.

- Change Engineering URV : Set up URV (Upper Range Value) which is used in LCD Engineering Mode.
 - Executing the menu to put Zero+Span button.

- Moving to the next menu to put Zero button when 1 TRIM message appear.
 - Moving to the next menu to put Zero button when 2 Setup message appear.
 - Moving to the sub directory to put Span button when 3 LCD message appear.
 - Moving to the next menu to put Zero button when 31 LCD-MD message appear.
 - Moving to the next menu to put Zero button when 32 DEC-PL message appear.
 - Moving to the sub directory to put Span button when 33 ENG-MD message appear.
 - Executing the function to put Span button when 331 EN-URV message appear.
 - LCD displays the present set-up value and the highest input DIGIT flickers.
 - The procedure of setting value is same as Zero Adjustment.
- Change Engineering LRV : Set up LRV (Lower Range Value) which is used in LCD Engineering Mode.
- Executing the menu to put Zero+Span button.
 - Moving to the next menu to put Zero button when 1 TRIM message appear.
 - Moving to the next menu to put Zero button when 2 Setup message appear.
 - Moving to the sub directory to put Span button when 3 LCD message appear.
 - Moving to the next menu to put Zero button when 31 LCD-MD message appear.
 - Moving to the next menu to put Zero button when 32 DEC-PL message appear.
 - Moving to the sub directory to put Span button when 33 ENG-MD message appear.
 - Moving to the next menu to put Zero button when 331 EN-URV message appear.
 - Executing the function to put Span button when 332 EN-LRV message appear.
 - LCD displays the present set-up value and the highest input DIGIT flickers.
 - The procedure of setting value is same as Zero Adjustment.
- Change Engineering Unit
- Executing the menu to put Zero+Span button.
 - Moving to the next menu to put Zero button when 1 TRIM message appear.
 - Moving to the next menu to put Zero button when 2 Setup message appear.
 - Moving to the sub directory to put Span button when 3 LCD message appear.
 - Moving to the next menu to put Zero button when 31 LCD-MD message appear.
 - Moving to the next menu to put Zero button when 32 DEC-PL message appear.
 - Moving to the sub directory to put Span button when 33 ENG-MD message appear.
 - Moving to the next menu to put Zero button when 331 EN-URV message appear.
 - Moving to the next menu to put Zero button when 332 EN-LRV message appear.
 - Executing the function to put Span button when 333 E-UNIT message appear.
 - The 1st position in the LCD lower part flickers while letters are entered to be used as the LCD

Engineering Unit.

- Letter input method is the same as numerical input method except "not only number but also letter and partly special character can be enter into each DIGIT". Hence, enter in the same procedure as in (4) Zero Adjustment.
 - Engineering Unit entered through button manipulation gives the same result as User Define Unit under the communication environment of STT30 or HHT (Handheld Terminal).
- Change Engineering Unit
- Executing the menu to put Zero+Span button.
 - Moving to the next menu to put Zero button when 1 TRIM message appear.
 - Moving to the next menu to put Zero button when 2 Setup message appear.
 - Moving to the sub directory to put Span button when 3 LCD message appear.
 - Moving to the next menu to put Zero button when 31 LCD-MD message appear.
 - Moving to the next menu to put Zero button when 32 DEC-PL message appear.
 - Moving to the sub directory to put Span button when 33 ENG-MD message appear.
 - Moving to the next menu to put Zero button when 331 EN-URV message appear.
 - Moving to the next menu to put Zero button when 332 EN-LRV message appear.
 - Moving to the next menu to put Zero button when 333 E-UNIT message appear.
 - Executing the function to put Span button when 334 E-TRF message appear.
 - Until the desired Transfer Function, either "LINEAR" or "SQRT", is displayed on the LCD lower part, push ZERO button repeatedly.
 - If the desired Transfer Function is displayed, push SPAN Button to complete set-up.
 - If "SAVE" is displayed, push SPAN Button to save set-up value.
- * This product can print out measured results in various ways on the LCD screen. LCD Engineering Mode is the function that converts measured result to "numerical value with different weight"and prints out on the LCD screen. LCD Engineering Mode sets up Engineering Range separately, and maps measured result (0~100%) to Engineering Range and prints out on LCD. For the measured value handling procedure in the LCD Engineering Mode, refer to [Figure3-10]. It should be noticed that both Transfer Function and ENG. Transfer Function cannot be simultaenously set up as SQRT.

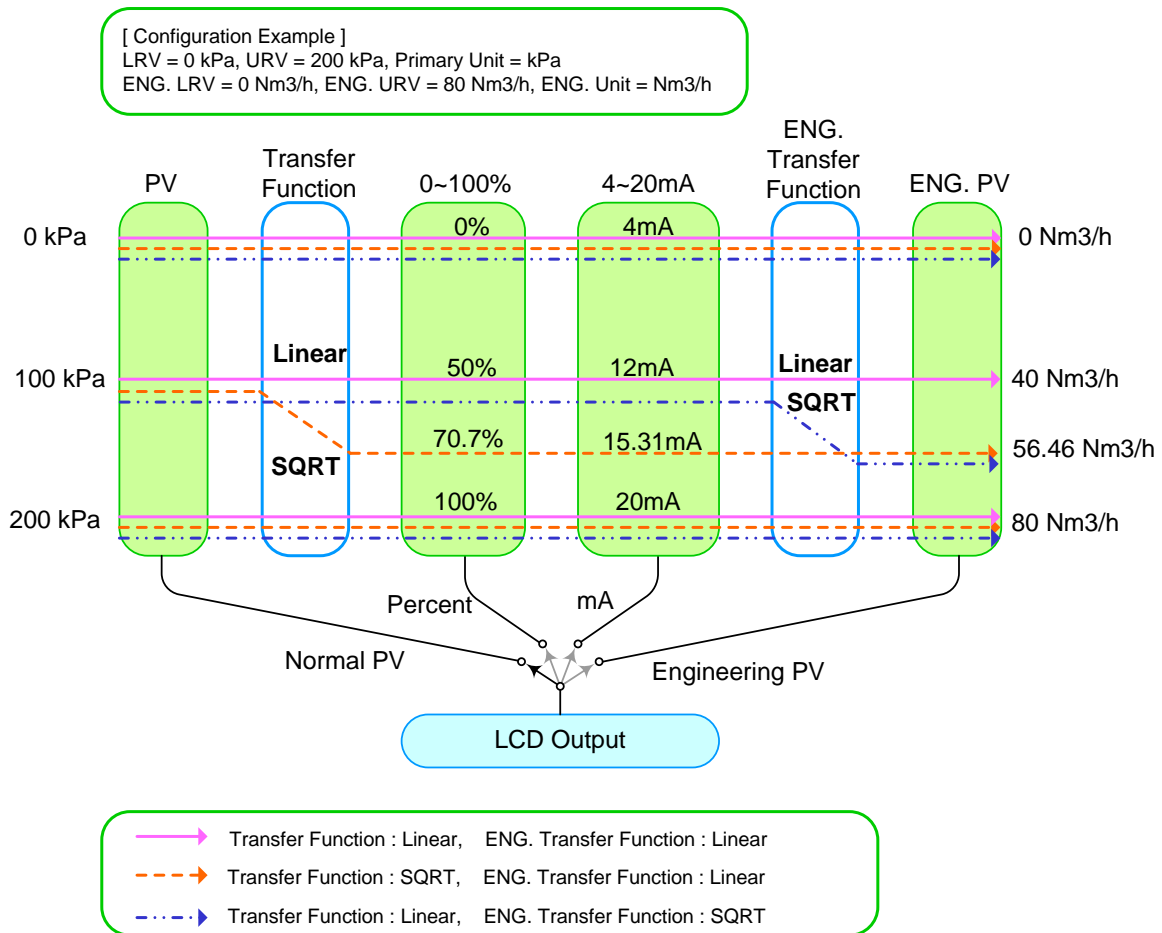

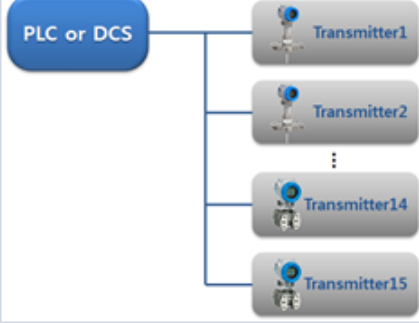

Figure 3-10. Measurement value handling procedure

- Select Button Lock
 - Executing the menu to put Zero+Span button.
 - Moving to the next menu to put Zero button when 1 TRIM message appear.
 - Moving to the next menu to put Zero button when 2 Setup message appear.
 - Moving to the next menu to put Zero button when 3 LCD message appear.
 - Moving to the sub directory to put Span button when 4 DEVICE message appear.
 - Executing the function to put Span button when 41 B-LOCK message appear.
 - Use ZERO button to choose either "LOCK" or "RELEAS" and, then, push SPAN.
 - If "LOCK" is chosen, enter the previous password after messages of "INPUT", "OLD", and "PASSWD". Then, enter new password after messages of "INPUT", "NEW", and "PASSWD", to set up Button Lock (Transmitter's initial password is "000000").
 - If "RELEAS" is chosen, you can cancel Button Lock by entering the existing password after messages of "INPUT" and "PASSWD".

- Letter input method is the same as numerical input method except “not only number but also letter and partly special character can be enter into each DIGIT”. Hence, enter in the same procedure as in (4) Zero Adjustment.
 - If “SAVE” is displayed, push SPAN Button to save set-up value.
 - * If Button Lock is set up, you have to enter password entering into menu Tree after messages of "INPUT" and "PASSWD", and if password is incorrect it is impossible to manipulate through menu Tree.
 - * If wrong password is entered, "PASSER" is displayed and, then, input is cancelled.
- Master Reset
 - Executing the menu to put Zero+Span button.
 - Moving to the next menu to put Zero button when 1 TRIM message appear.
 - Moving to the next menu to put Zero button when 2 Setup message appear.
 - Moving to the next menu to put Zero button when 3 LCD message appear.
 - Moving to the sub directory to put Span button when 4 DEVICE message appear.
 - Moving to the next menu to put Zero button when 41 B-LOCK message appear.
 - Executing the function to put Span button when 42 M-RST message appear.
 - If SPAN Button is pushed after displaying of “SAVE”, Transmitter is reset after a while (Equivalent to turning on and off power).
 - Change HART Polling Address : Set up Polling address for HART communication.
 - Executing the menu to put Zero+Span button.
 - Moving to the next menu to put Zero button when 1 TRIM message appear.
 - Moving to the next menu to put Zero button when 2 Setup message appear.
 - Moving to the next menu to put Zero button when 3 LCD message appear.
 - Moving to the sub directory to put Span button when 4 DEVICE message appear.
 - Moving to the next menu to put Zero button when 41 B-LOCK message appear.
 - Moving to the next menu to put Zero button when 42 M-RST message appear.
 - Executing the function to put Span button when 43 P-ADDR message appear.
 - LCD displays the present Polling Address, which increases to 0~15 every time ZERO Button is pushed. After choosing a Polling Address in the range of 0~15, push SPAN Button.
 - If “SAVE” is displayed, push SPAN Button to save set-up value.
 - * If Polling Address is not 0, HART communication is operated in Multidrop, and at the time of setting up Multidrop, M-icon is displayed on the LCD upper part.

	Point to Point	Multidrop
Topology		
Polling Address	0	1 ~ 15
Current Output	4~20mA	4mA Fixed

[Figure 3-11 HART communication topology]

3.8 Shop Commissioning using HHT

Commissioning consists of testing the transmitter, testing the loop, and verifying transmitter configuration data. APT-3100 Pressure Transmitter may be commissioned using HHT of HART supported either before or after installation.

▲ If you connect "TEST" pin, it's not communicated. If it doesn't exposed electronics circuits after install, you must connect all Jumper of transmitter in the shop commissioning level. Analog output of transmitter is 4~20 mA, thus it requires Power Supply at 24V (12 V ~ 45 Vdc) and Ampere meter for measuring output current. You must connect 250~550 ohm resistor in Power Loop for HART Communication and HHT or PC Configurator.

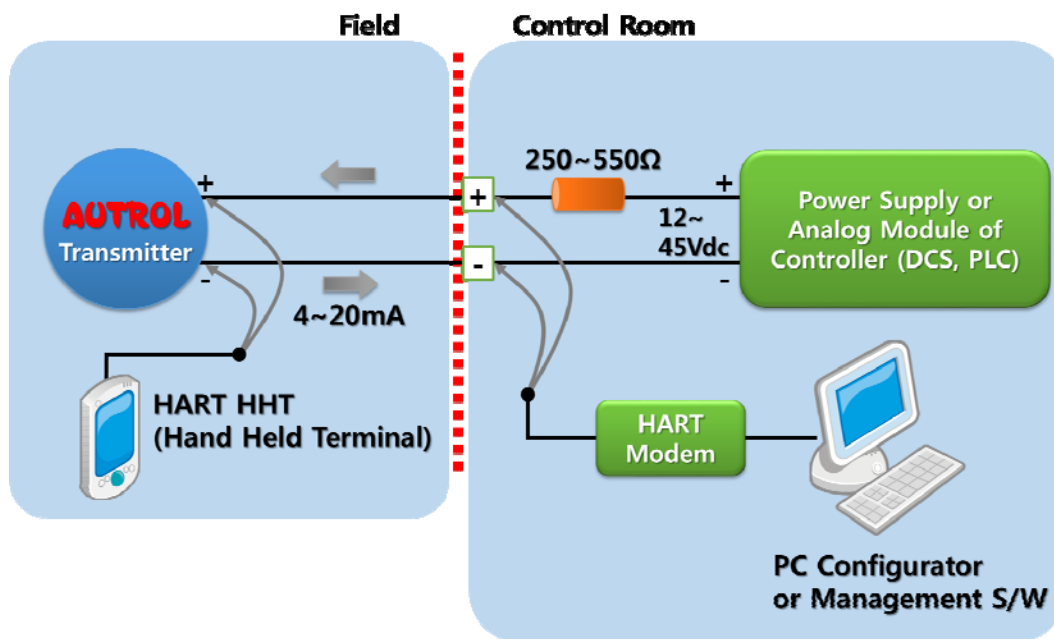

[Figure 3-5 Connection the transmitter to

- 1) HHT(Hand Held Terminal) or PC Configurator may connected at any termination point in the signal loop
 - 2) HART Communication requires a loop resistance between 250~550 ohm @ 24Vdc.
 - 3) Transmitter operates on 12 to 45.0 Vdc Transmitter terminal voltage.
- [Applied Power]
- 12~45.0 Vdc for General operation
 - 17.5~45.0 Vdc for HART Communication (@250ohm)

Chapter 4 Installation

4.1 Overview

The information in this chapter 4 covers installation considerations. Dimensional drawings for Model APT-3100 variation and mounting configuration are included in this chapter.

4.2 Safety Message

Procedures and instructions in this chapter may require special precautions ensure the safety of the personnel performing the operation. Information that raises potential safety issues is indicated by a warning symbol(▲). Refer to the following safety messages before performing an operation proceeded by this symbol.

4.3 Warning

▲ Warning

Explosion can result in death or serious injury :

- ◆ Do not remove the transmitter covers in explosion environments when the circuit is alive.
- ◆ Both transmitter covers must be fully engaged to meet explosionproof requirements

▲ Warning

Electrical can result in death serious injury:

- ◆ The qualification which is educated only the person whom it prepares will be able to establish the transmitter.

▲ Warning

Process leaks can cause death or serious injury:

- ◆ Install and tighten before applying pressure. If you don't like this, it can cause process leaks.

▲ Warning

Electrical shock can result in death or serious injury. If you install high voltage environment or false condition, power line and lead will be appered high voltages.

- ◆ Avoid contact with the leads and terminals.

4.4 Commissioning on the bench with Hand-Held Terminal

After and before installation, you can handle upon commissioning. However, for correctly handling and knowing the function, before installation you have to handle upon commissioning on the bench with Hand-Held Terminal.

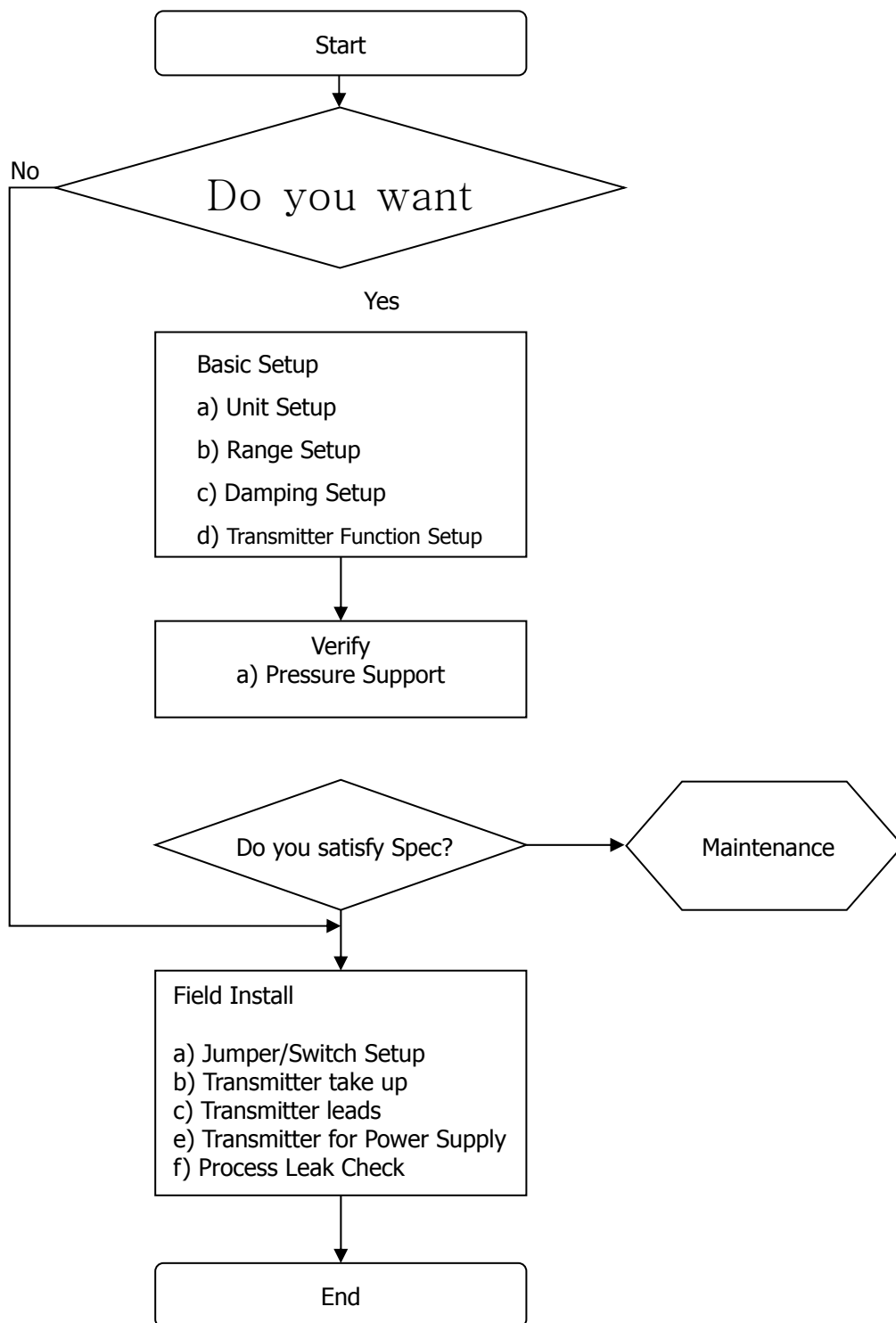

[Figure 4-1 Installation Flow Chart]

4.5 General Considerations

This transmitter uses the capacitive pressure sensor. If it changes the pressure sensor, capacitive pressure is changed minutely.

It transfer electrical signal minutely to 4~20mA analog signal. Thus mount the transmitter close to the process and use a minimum of piping to achieve best accuracy. However keep in mind the need for easy access, safety of personnel, practical field calibration, and a suitable transmitter environment.

In general, install the transmitter so as to minimize vibration, shock, and temperature fluctuations.

4.6. Electrical Considerations (Power Supply)

The transmitter housing composes of two parts. One side is electronics circuit, and other side is Terminal Block. Terminal Block side is transmitter's frontside and is indicated " Field Terminal" in transmitter housing external. Open this side's housing cover, there is Terminal Block in housing inside. Consider to this Terminal Block polarity, connect to Transmitter's Power Supply. Configurator supported HART connects to "COMM" pin in Power Supply downside. In the field Indicator connects to "TEST" pin.

4.6.1 Power Supply

In the transmitter's power supply Input Current Voltage is currently DC voltage between DC 12 volt ~ 45 volt and power supply's ripple is not up to 2%. Loop resistance means all resistor sums in loop.

In case of using Intrinsic Safety Barrier, same includes resistor of barrier.

$$\text{Max. Loop Resistance } [\Omega] = (E-12) [\text{vdc}] / 0.022 [\text{mA}]$$

Here, loop resistance is preferable at 250 ~ 550 Ω (24 Vdc) for the HART communication.

4.7. Wiring

4.7.1 Caution of Wiring

- (1) Install cable in the far from electrical noise resources like capacitive transformer, motors power supply as soon as possible.
- (2) Before wiring put out electrical lead connect cap.
- (3) All screw-lined portions paste suture for waterproof. (It promotes the silicon type that is not hardened.)
- (4) Don't lead signal line to power line in same duct for no received noise signal.
- (5) The explosion-proof transmitter in order to maintain the explosion-proof quality of the corresponding transmitter effectively follows in the demand explosion-proof specification that is provided and must be lead.

4.7.2 Selecting the Wiring Materials

- (1) Use over 600V PVC shielded wire or standard lead line of same class or cable. (In order to ensure proper communication use 24 AWG or lager wire, and do not exceed 1500 meters.)
- (2) Use the shielded wire in electrical noise effected area.

- (3) At the higher or lower temperature area than ambient temperature it uses the wire or the cable that is suitable like that temperature.
- (4) You have to use suitable wire, cable in environment like oil, solvent, toxic gas or liquid.
- (5) Terminal process of lead line must use to not soldered terminal lug. Recommend isolating lead end terminal using contract tube.

4.7.3 Connections of External Wiring to Transmitter Terminal Box

Wiring method is following this.

- ▲ (1) Open the housing cover indicated "FIELD TERMINAL". In explosion environment when circuit is powered on, don't open the covers.
- ▲ (2) Connect the power supply in the terminal indicated "+PWR"(left terminal) and "-" power supply in the central terminal. Don't connect "+" power supply in "+" terminal of the point indicated "TEST". It will be damage to test diode used to connecting TEST terminal.
- (3) Seal and close the non-using Conduit Connection Part for severe humidity and explosion on the terminal box of housing.
- (4) Transmitter power is supplied to Signal Wiring. So, don't install near to Signal Wiring with Power Wiring or near to Power Apparatus. In case of ground signal, ground the signal loop's one side and other side is not grounded. Promote to ground "-" side of power.
- (5) For the better adjustment completely turn Screw terminal.
- (6) Again close the transmitter cover. Specially in case of using in explosion area, you must to satisfy requirement about explosion.

[Note]

Don't supply high voltage (AC power) in transmitter leads. It can be caused damages to transmitter.

- (7) You have to connect 250~600 W Loop Resistor in Current Loop(between Power Supply and Transmitter) for HART Communication HART. Following Figure 4-2 about conection of Current Loop.

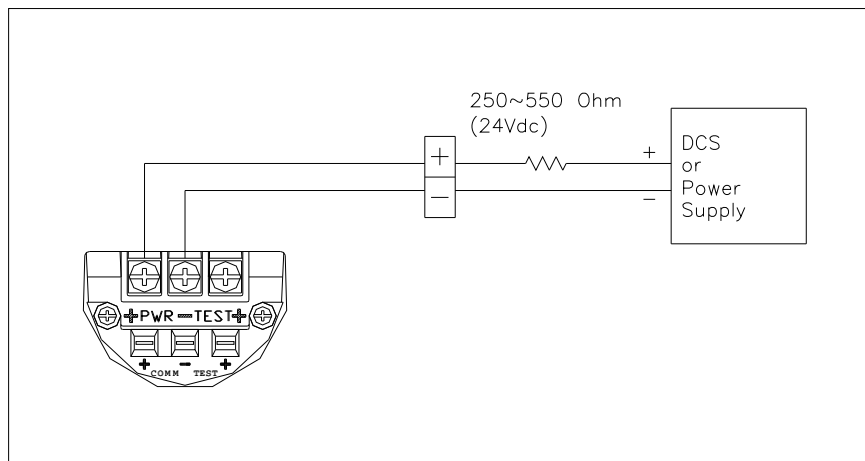

Figure 4-2 Connection with Terminal Board of Transmitter

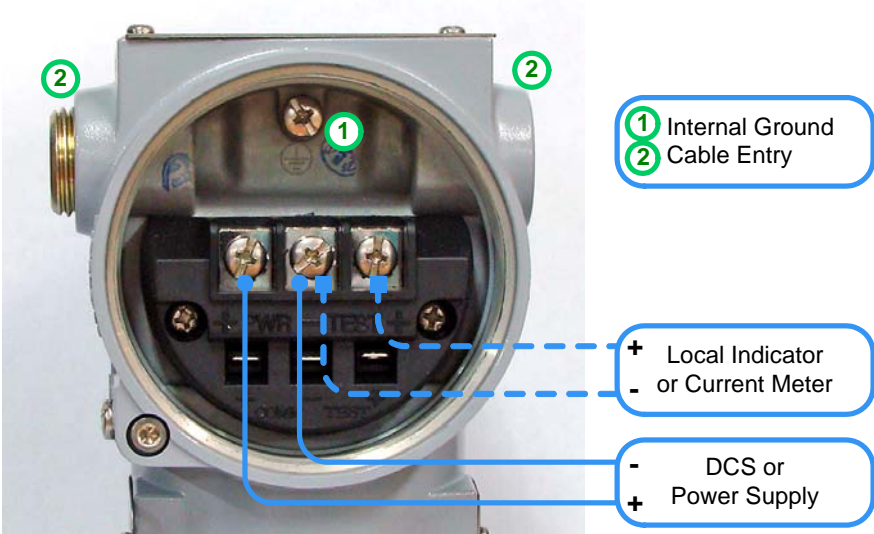

Figure 4-3 Picture of Terminal Board of Transmitter

4.7.4 Wiring

▲ Warning

Explosion can result in death or serious injury:

- ◆ Do not remove the transmitter covers in explosion environments when the circuit is alive.
- ◆ Before connection HHI in explosion zone, confirm that the configure device has to be installed by intrinsic safety regulations.
- ◆ Both transmitter covers must be fully engaged to meet explosion proof requirements

A. Loop Configuration

AUTROL Series Transmitters use a two-wire system for power supply, 4~20mA analog signal transmission and HART digital transmission. DC Power Supply is required for the transmitter loop. The Transmitter and distributor are connected as shown below.

(1) Non-Explosionproof / Flameproof Type

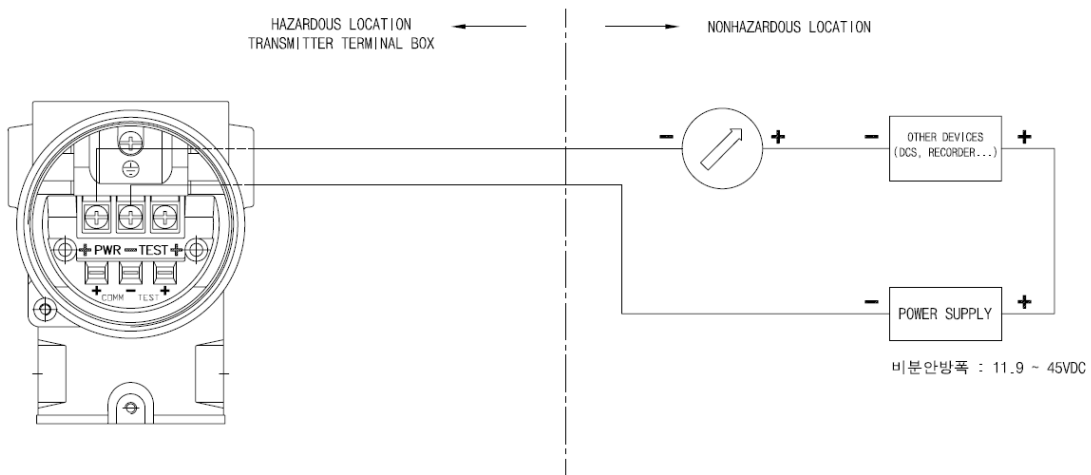

(2) Explosionproof Type

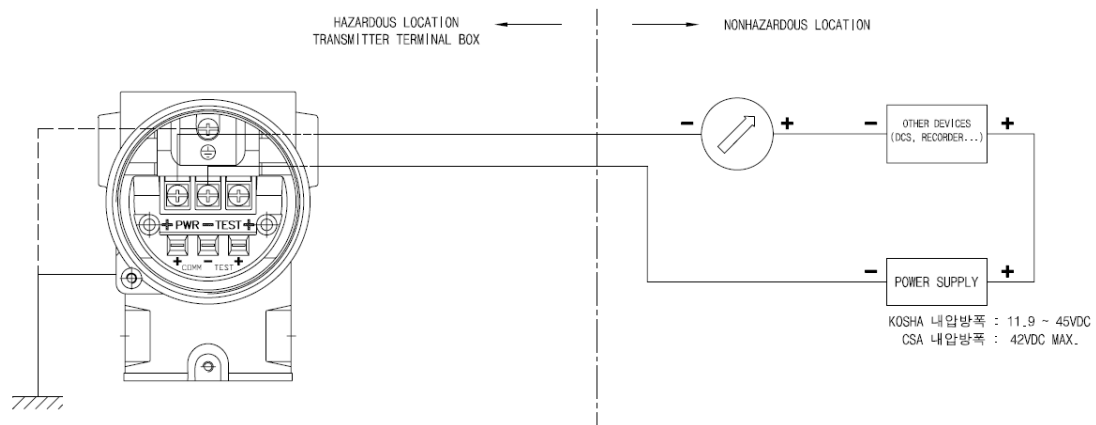

(3) Intrinsic Safety Type

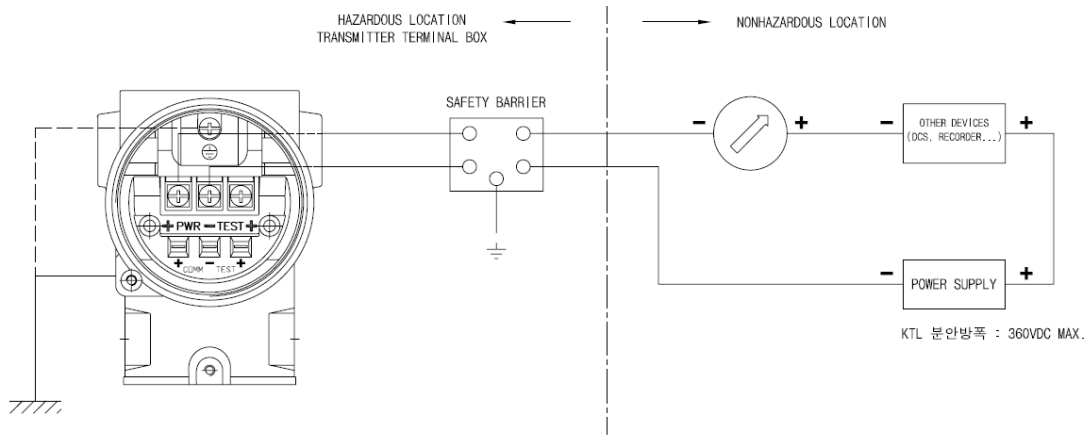

[Figure 4-3 Connection between Transmitter and Power Supply]

B. Wiring Installation

- (1) General-use Type and intrinsically Safe Type
Make cable wiring using metallic conduit or Waterproof cable glands.

- o. Apply a non-hardening sealant to the terminal box connection port and the threads on the flexible metal conduit for the waterproofing.

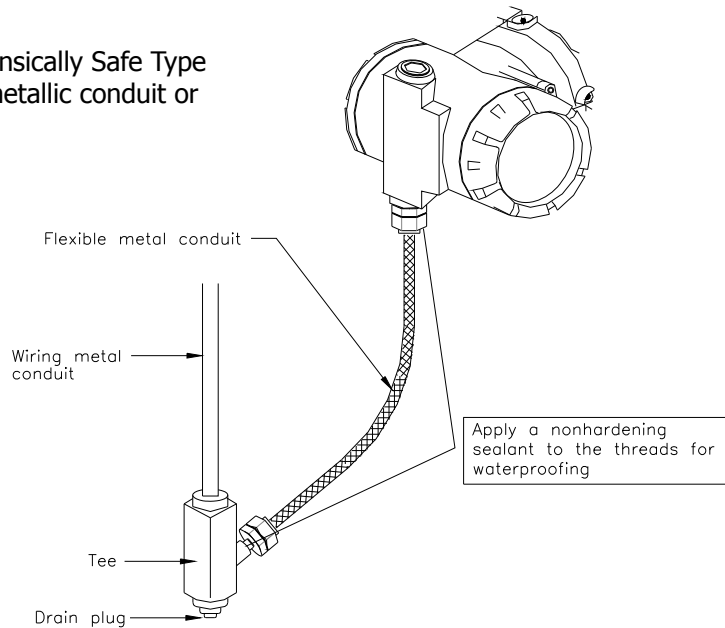

[Figure 4-4a
Typical Wiring using Flexible Metal Conduit]

- (2) KOSHA Flameproof Type

Wire cables through a flameproof packing adapter, or using a flameproof metal conduit.

- (a) Wiring cable through flameproof packing adapter for KOSHA flameproof type (see Figure 4-4b)
 - ◇ Use only flameproof packing adapter by KOSHA.
 - ◇ Apply a non-hardening sealant to the terminal box connection port and to the threads on the flameproof packing adapter for waterproofing
 - ◇ Mounting flameproof packing adapter to the terminal box.
 - o. Screw the flameproof packing adapter into the terminal box until the O-ring touches the terminal box wiring port (at least 5 full turns), and tighten the lock net.

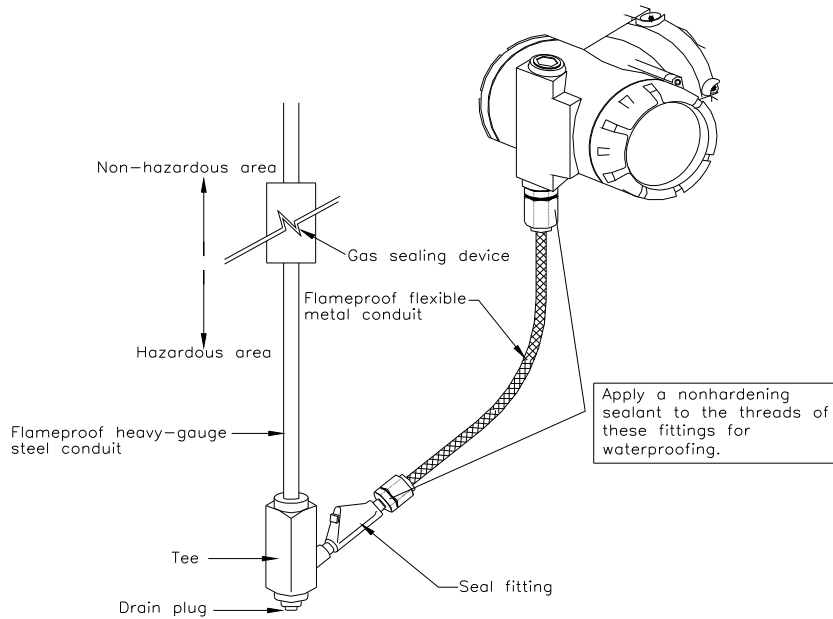

After wiring, impregnate the fitting with a compound to seal tubing.

[Figure 4-4b
Typical Wiring using Flameproof Packing Adapter]

(b) Flameproof metal conduit wiring (Figure 4-4c)

- ◇ A seal fitting must be installed near the terminal box connections port for a sealed construction.
- ◇ Apply a non-hardening sealant to the threads of the terminal box connection box, flexible metal conduit and deal fitting for waterproofing.

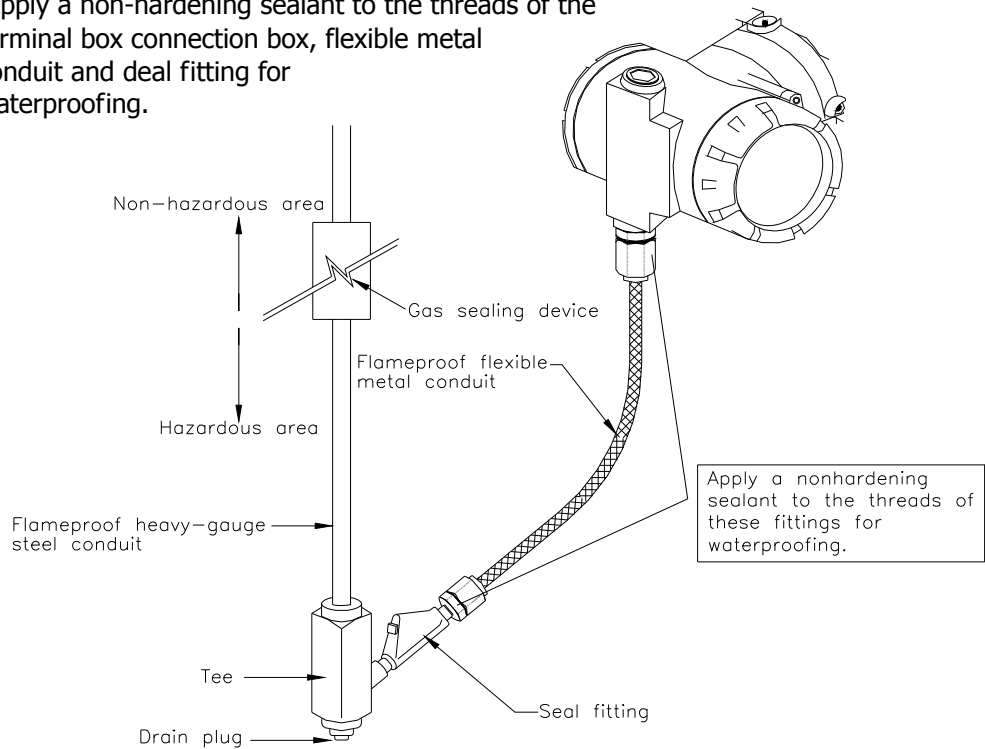

After wiring, impregnate the fitting with a compound to seal tubing.

[Figure 4-4c
Typical Wiring using Flameproof Metal Conduit]

4.7.5 Grounding

- (a) Grounding should satisfy KS requirements (grounding resistance, 10 Ohm or less). Grounding is required below 10 Ohm for explosionproof and intrinsic safety.

[Note] In case of with Built-in Lightning Protector, Grounding should satisfy Special KS requirements (grounding resistance, 10 Ohm or less)

- (b) There are ground terminal on the inside and outside of the terminal box. Either of these terminals may be used.

- (c) Use 600V grade PVC insulated wire for grounding.

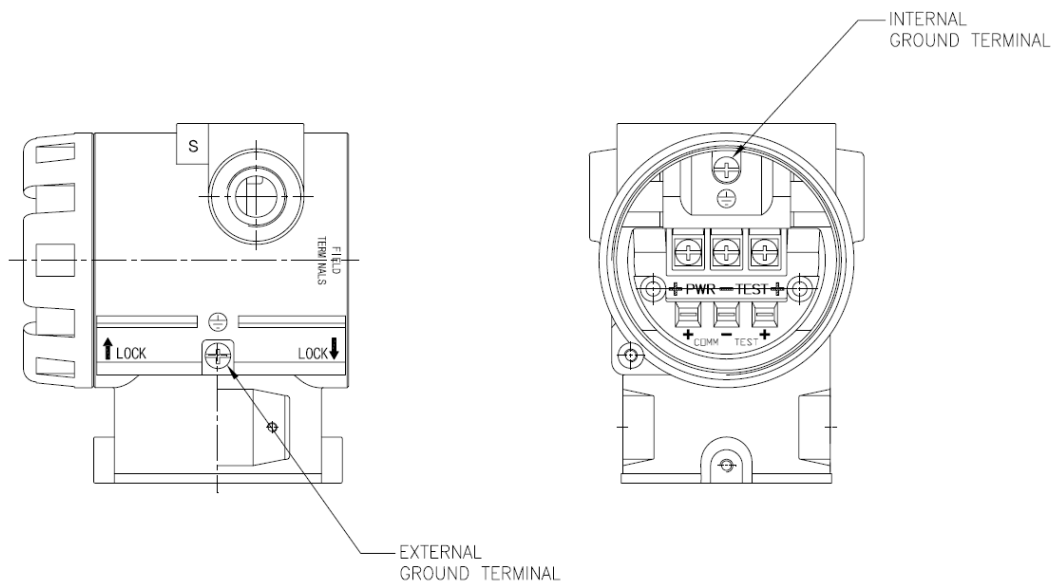

APT3100 SMART PRESSURE TRANSMITTER
INTERNAL AND EXTERNAL GROUND TERMINAL

4.7.6 Power Supply Voltage and Load Resistance

When configuring the loop, make sure that the external load resistance is within the range in the figure below. Since the voltage of transmitter terminal input is same as follows.

- Voltage Rating : 24Vdc
- General Standard : 12 to 45 Vdc
- Hart Communication : 17.5 to 45 Vdc
- KOSHA Explosionproof: 12 to 45 Vdc
- CSA Explosionproof : 17.5 to 42 Vdc max.

And maximum loop current is 24mA, Load resistance R:

$$R = (E-12) / 0.022 \quad (E = \text{Power Supply Voltage})$$

[Note] In case of an intrinsically safe transmitter, external load resistance includes safety barrier resistance.

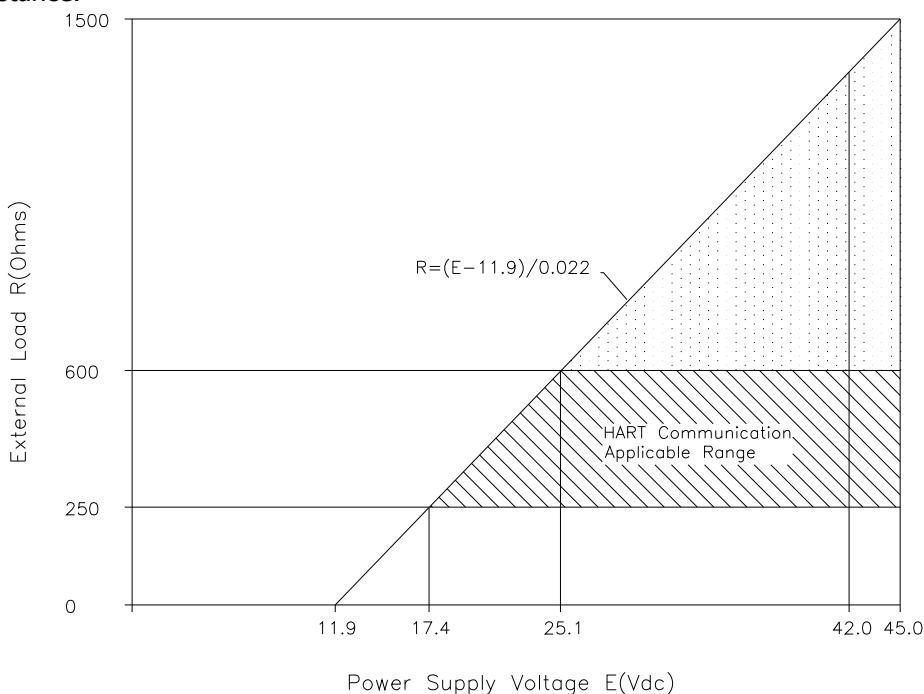

4.8 Mechanical Considerations

Figure 4-3 is transmitter dimensional drawings of APT 3500. A mounting example and dimensional drawings is shown in Figure 4-4.

[Standard Model]

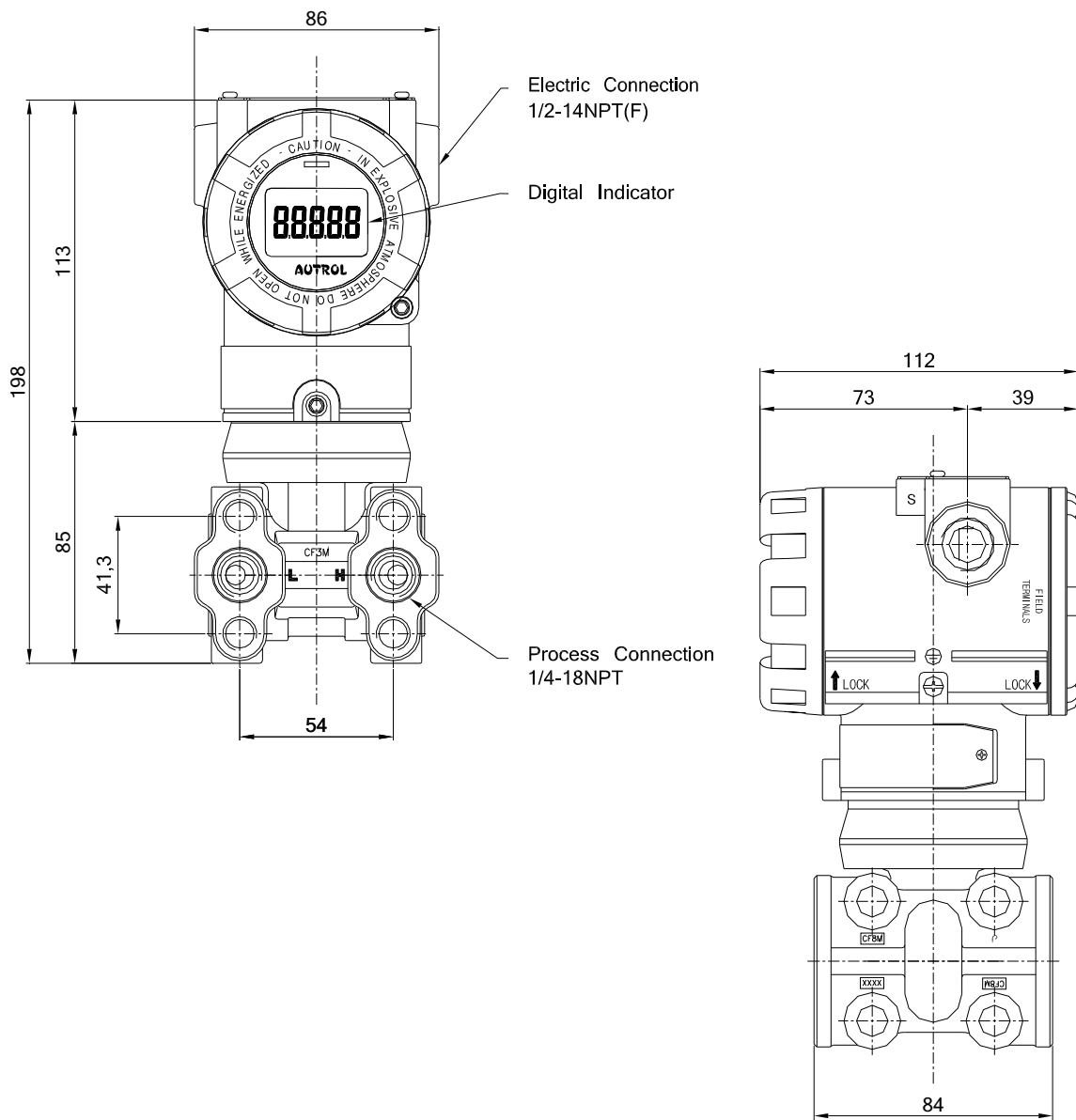

[MP Flange]

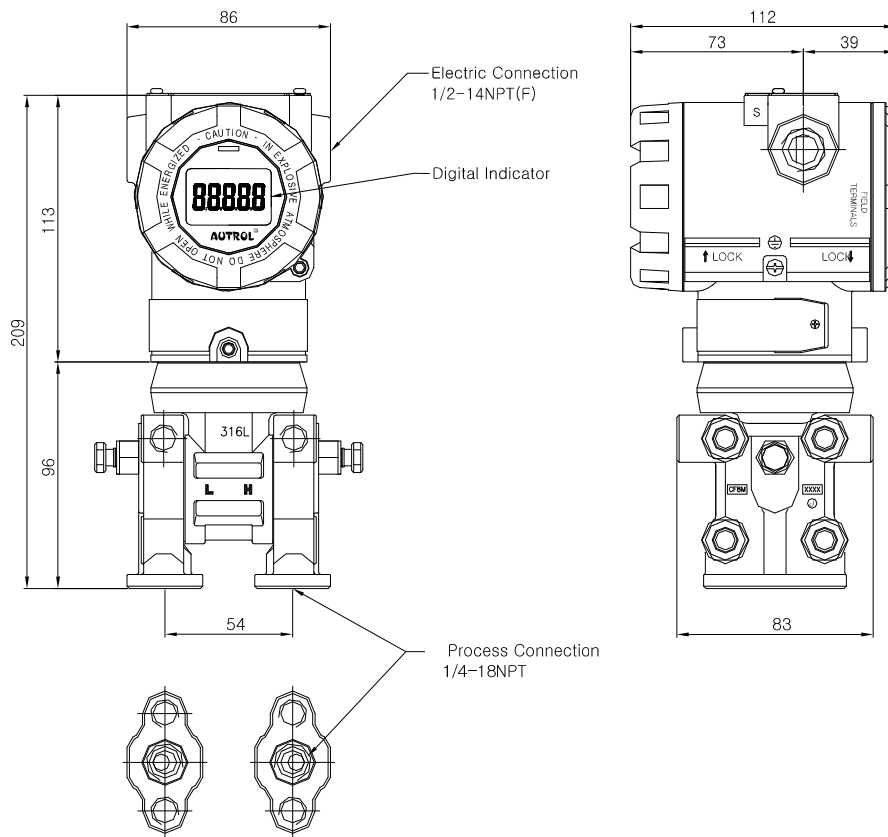

[High Static Pressure Model]

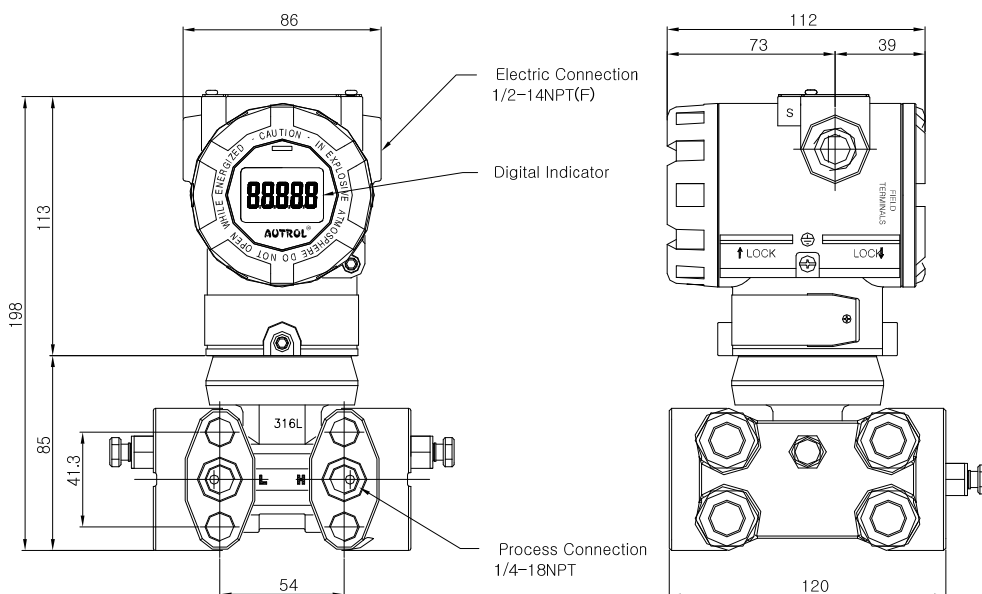

Figure 4-6. Model APT 3500 Outline Dimension Drawing

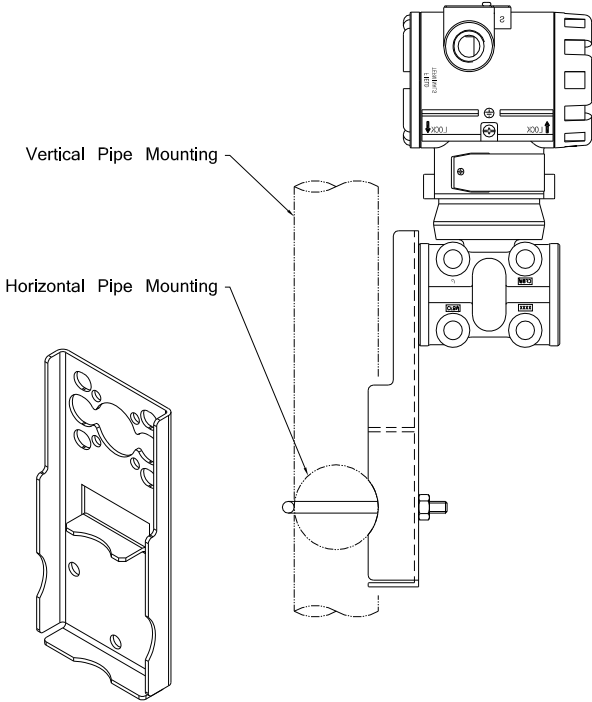
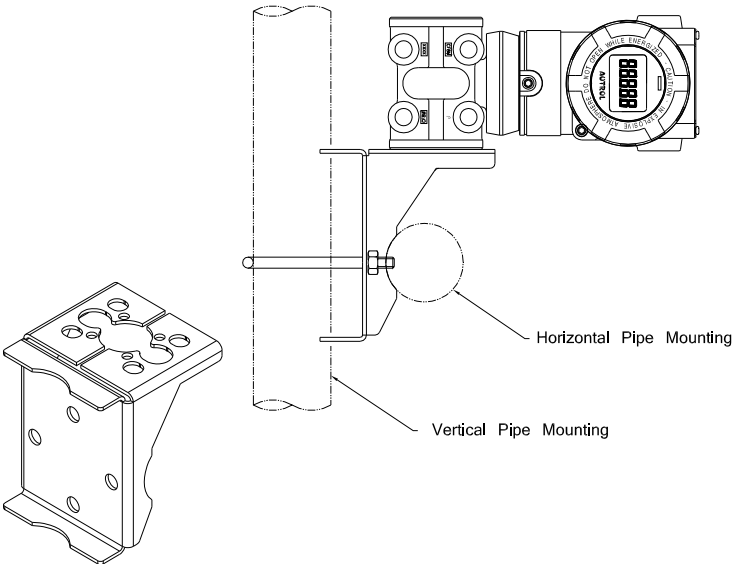

Figure 4-7. Typical Bracket Mounting

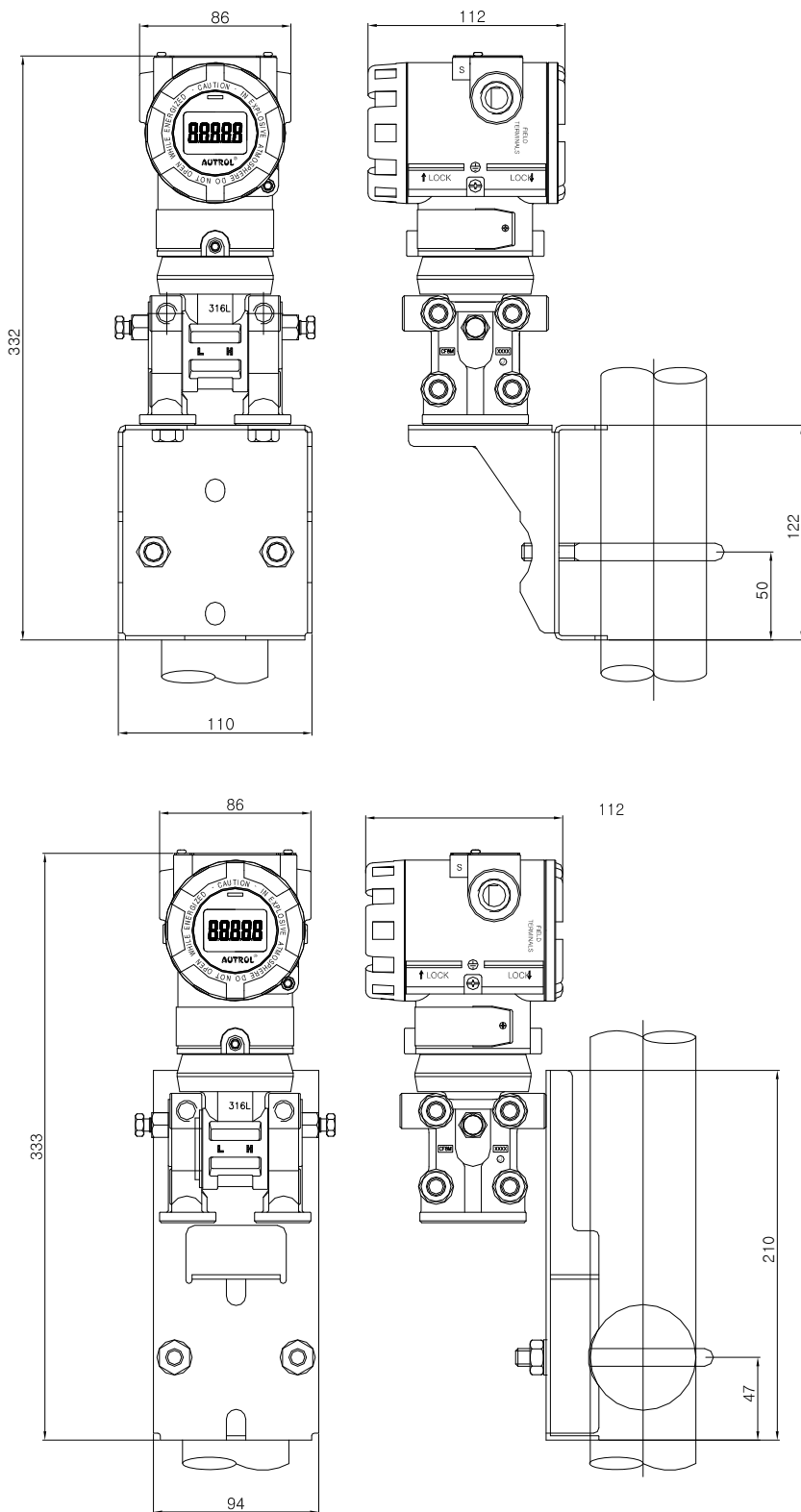

Figure 4-8. MP Option Bracket Mounting

4.8.1 Mounting

To use the cadence carrier from the environment where the vibration is heavy and must install the transmitter. In the environment where the vibration is heavy you will have to install the transmitter by using an assistant support. In the case of severe vibration, promote to mount on pipe using a mounting bracket as option.

4.8.2 Consideration of Transmitter Access

When selecting the establishment location or a place of the transmitter, it treats the transmitter it probably is a location that is convenient must consider.

- ① Rotation of housing: housing can be rotated up to 90°.
- ② Terminal sides of transmitter: location ease us terminal space where be able to pull out transmitter cover
- ③ Circuits side of transmitter: the space where there is a possibility of treating a electronic circuit / the space where be able to pull out transmitter cover / If LCD meter is installed, it requires extra space.

4-8-3. Housing Rotation and Lock Screw

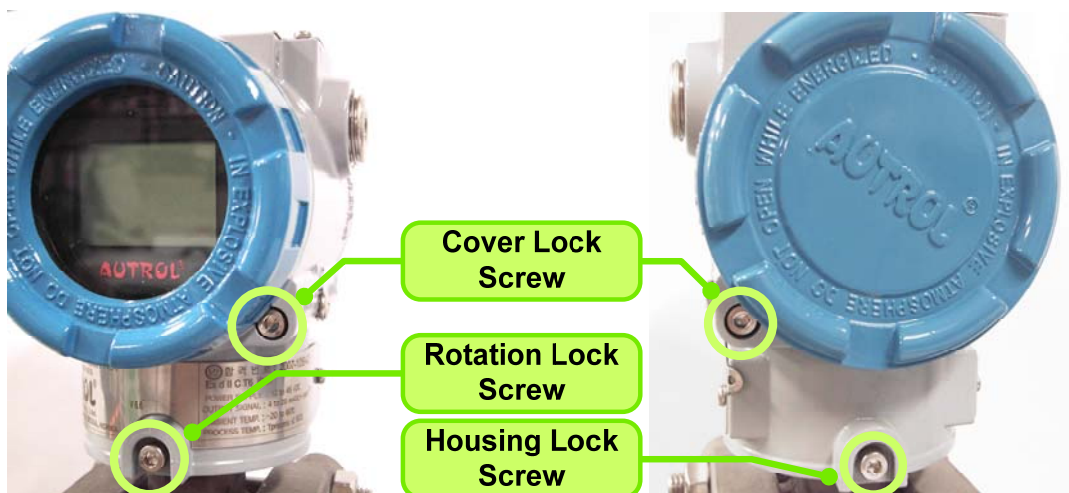

Figure 4-8. Lock Screw

After Transmitter installation, housing can be rotated for wiring work or adjusting indication direction of indicator. To rotate housing, loosen Rotation Lock Screw and rotate housing to the desired direction. After completing housing direction adjustment, do not forget to tighten Rotation Lock Screw to fix housing.

<Note> Housing is mechanically designed to be rotated up to 360°. In case of forced rotation exceeding the limit, Transmitter may be damaged.

After completely removing Rotation Lock Screw and Housing Lock Screw, it is possible to separate housing and sensor body of Transmitter by rotating housing. But, internal electronic boards should be removed in advance before separating housing and sensor body.

Cover Lock Screw fixes the front and rear covers to prevent them from loosening. Fully loosened, the Screw is stuck to the Cover side and Cover is fixed not to turn. Closing Cover Lock Screw again, you can open it by turning Cover.

4.9 Environmental Considerations

4.9.1 Effect of Ambient Temperature

You have to install at $-20^{\circ}\text{C}\sim 60^{\circ}\text{C}$ ($-4\sim 180^{\circ}\text{F}$), operating ambient temperature range. If predicted heat seems to exceed or equivalent to ambient temperature range limit, you have to consider additional method to cutoff the process heat.

4.9.2 Environment of toxic, moisture

Housing of APT-3100 can be protected to moisture or toxic material. Electronic circuit side is separating from terminal side. When O-ring Seal cover covers, it is intrinsic safety. But, some drip could penetrate to the housing of transmitter through conduit pipeline. Therefore, transmitter should be set up over the position of conduit pipe for preventing drip.

4.9.3 Installation of dangerous place

Transmitter is designed to explosion-proof housing. Installation environment of transmitter must be confirmed explosion-proof specification.

Chapter 5 On-line Operation

5.1 Overview

This chapter describes to configure function of APT 3500 SMART Pressure Transmitter. Transmitter can be configured to On-Line or Off-Line mode. In On-Line Configuration Mode, you must connect configuration such as HHT (Hand Held Terminal), etc. Configuration data inputs in Working Register of HHT and this data is sent to corresponding transmitter.

5.2 Safety Message

Send operation. Do specially notice for safety of operator. In damage and place required specially safety, We indicate Warning symbol(▲). When you operate work of Warning symbol, follow Safety Message.

5.2.1 Warning

▲ Warning
<p>Explosion can result in death or serious injury:</p> <ul style="list-style-type: none"> ◆ Do not remove the transmitter covers in explosion environments when the circuit is alive. ◆ Before connecting HHT in explosion zone, confirm that the configure device has to be installed by intrinsic safety regulations. ◆ Both transmitter covers must be fully engaged to meet explosion-proof requirements

▲ Warning
<p>Electrical shock can result in death or serious injury. If you install high voltage environment or false condition, power line and lead will be appeared high voltages.</p> <ul style="list-style-type: none"> ◆ Avoid contact with the leads and terminals.

5.2.2 Configuration current to passive mode

In the case of short Current Loop, send or request data to change transmitter output you must configure Current Loop to passive mode. Don't believe in message indicating HHT, must configure Current Loop to passive mode with other operation.

5.3 Configuration Data Review

In case of install transmitter in fact site, before operate transmitter reexamine and certify whether configuration data correspond with fact application environment.

5.4 Check Output

Before other handle transmitter to on-line, you must examine and confirm whether transmitter currently operate and suitably configure progress variable.

5.4.1 Process Variable

We use two progress variable in APT-3100 SMART Pressure Transmitter pressure value is Primary Variable and temperature value of pressure value configure SV(Secondary Variable) with fixed value.

Moreover this PV value ouputs with 4~20mA analog value.

5.5 Basic Setup

You must configure correlation variable for operating currently transmitter.

5.5.1 Select Sensor Range

Pressure range to measure is depended Range Code of sensor. This value is classified from pressure sensor module automatically.

5.5.2 Set Output Units

Select from the following engineering units:

Unit: kPa, kg/cm², bar, psi, mmH₂O etc

5.5.3 Rerange

Set the Zero and Span of 4~20mA analog output.

5.6 Detailed Setup

5.6.1 Set Fail Mode

When sensor is wrong or microprocessor of transmitter doesn't operate normally in order to outputs current value of High or Low.

5.6.2 Set Damping Time

The sensor input value changes the response time of the transmitter to smooth variations in output readings caused by rapid changes in input. Determine the appropriate damping setting based on the necessary response time, signal stability, and other requirements of the loop dynamics of your system. The default damping value is 1.0 seconds, and can be reset to damping values between 0 and 60 seconds.

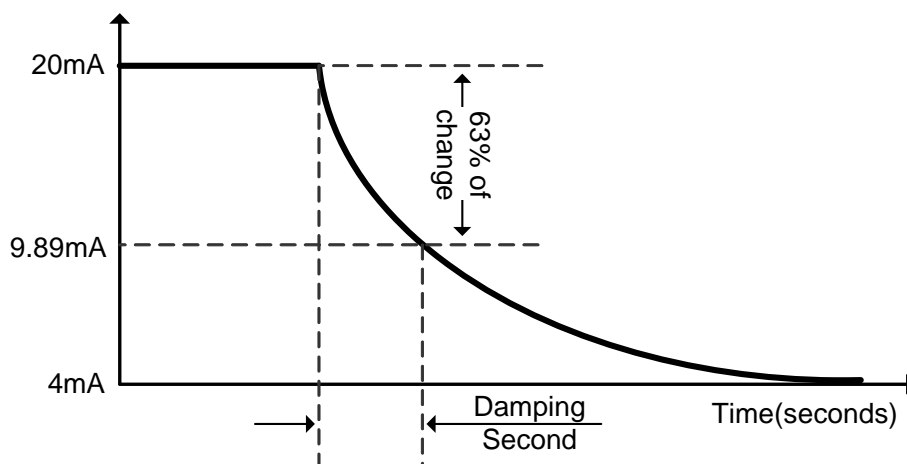

[Graph of Damping Second]

5.7 Configuration of Information Variable

5.7.1 Set Tag

Tag variable is better easy method to classify to transmitter in multi transmitter install environment. Tag Character can be used to 8 word of English/number.

5.7.2 Set Messages

When use several transmitter, user can define for classification each transmitter and use 32 words of English/number. This message is saved in EEPROM of transmitter.

5.8 Configuration of Breakdown Diagnostic Function

5.8.1 Loop Test

The Loop Test verifies the output of the transmitter, the integrity of the loop, and the operations of any recorders or similar devices installed loop. Perform the following procedure for a loop test.

- ① Connect a reference meter to the transmitter.
- ② Select the Loop Test of HHT and operate the Loop Test.
- ③ Select output current (4mA/20mA/etc)
- ④ If the readings match, then the transmitter and the loop are configured and functioning properly. If the readings do not match, then you may have the current meter attached to the wrong loop, there maybe a fault in the wiring, the transmitter may require an output trim, or the electrical current meter may be malfunctioning.

5.9 Calibration

Scaled system implement by calibrating the transmitter. Trim function have several function for the

calibration. Smart transmitters operate differently than analog transmitter. A Smart transmitter uses a microprocessor that contains information about the sensor's specific characteristics in response to pressure and temperature inputs for calculating Process Variable. The trim and rerange functions also differ. Reranging sets the transmitter analog output to the selected upper and lower range points and can be done with or without an applied pressure. Reranging does not change the factory characterization curve stored in the microprocessor. Sensor trimming requires an accurate pressure input and adds additional compensation that adjusts the position of the factory characterization curve to optimize transmitter performance over a specific pressure range. Rerange functions provides ability to readjust the 4~20mA points sensor inputs.

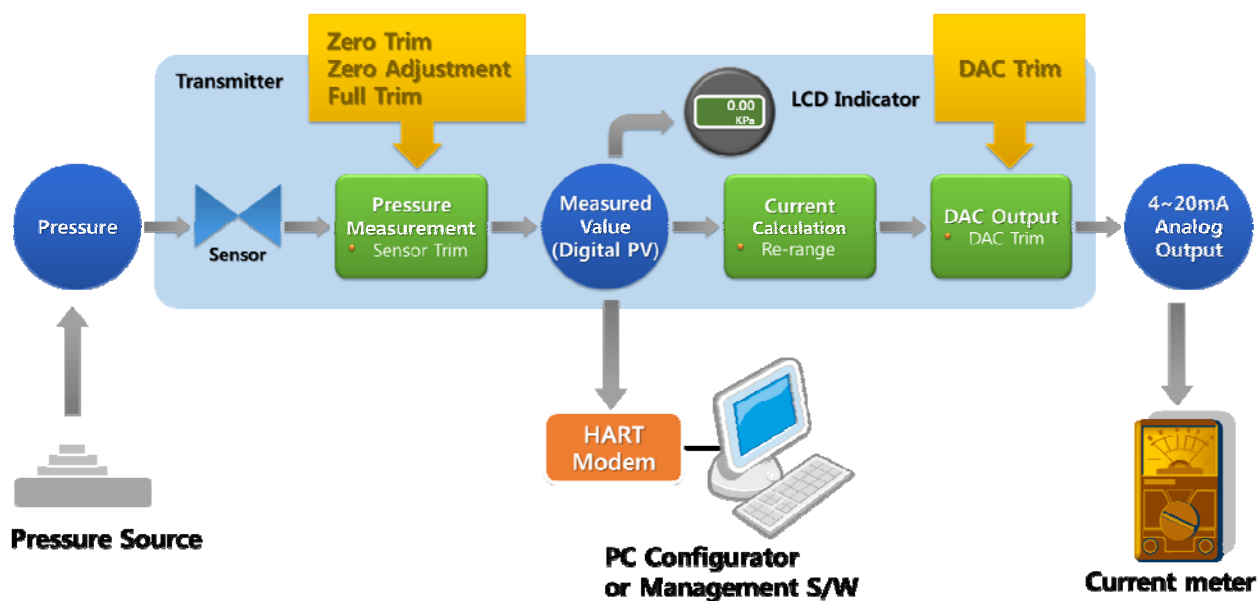

Figure 5-2. Calibration Environment

Detailed Calibration Procedure is as follows:

- 1) In the complete vent mode without pressure approval, check measured value of HHT or PC Configurator.
- 2) After approving the pressure to be checked (in general URV) from the pressure source, check measured value of HHT or PC Configurator and compare it with approved pressure.
- 3) After examining measured values, if the error turns out to be offset component execute Zero Trim or Zero Adjustment, and if slope is changed execute Full Trim. After Trim, check measured values again.
- 4) In the same method, check ampere meter in the vent mode and pressure approval mode.
- 5) In the event of error to measured values, check out the Transmitter set-up state, such as set-up range (URV, LRV), Transfer function, and Lowcut.
- 6) In the event of error to ampere meter even after checking set-up value, execute DAC Trim. After Trim, check measured values again.

Figure 5-3 shows the above Calibration Procedure.

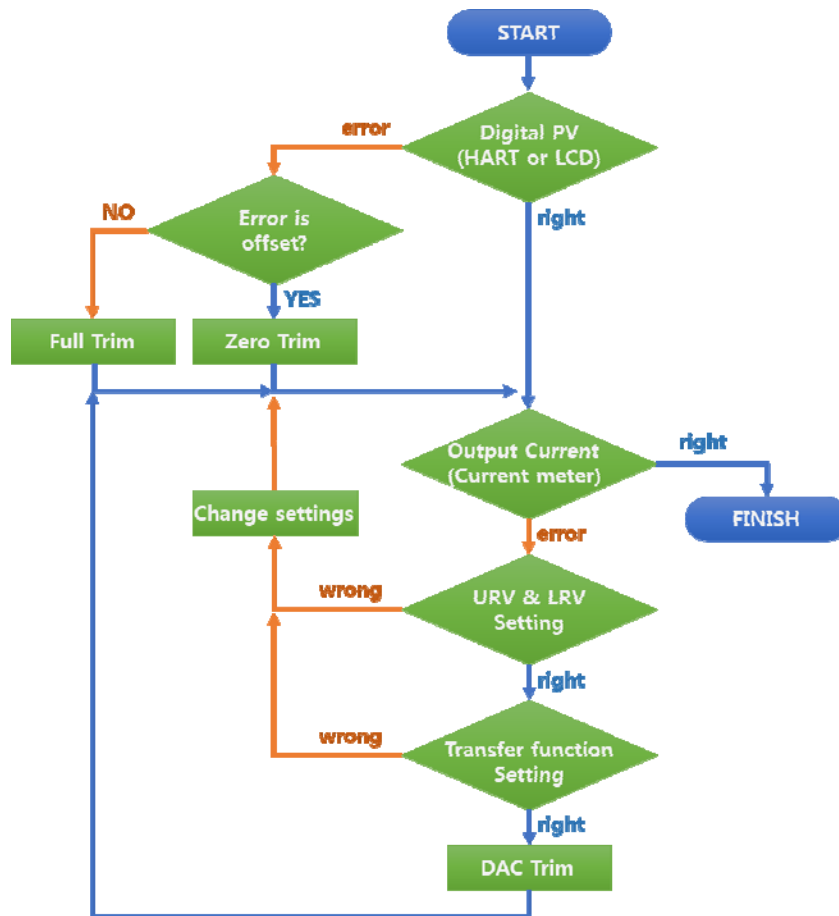

Figure 5-3. Calibration Procedure

5.9.1 Sensor Trim

The Sensor Trim the transmitter sensor input signal convert A/D to lead and how it interprets the values which it inputs with digital the contents of such interpretation and it is regarding to change is connected actually in the sensor which in order to correspond.

There are three waysto trim the sensor: Sensor zero trim, full trim and zero adjustment.

Sensor zero trim is a one-point adjustment typically used to compensate for mounting position effects or zero shifts caused by static pressure.

Two point trim is a full sensor tirm, in which two accurate end-point pressure are applied (equal to or greater than the range values), and all output is linearized between them. You should always adjust the low trim value first to establish the correct offset.

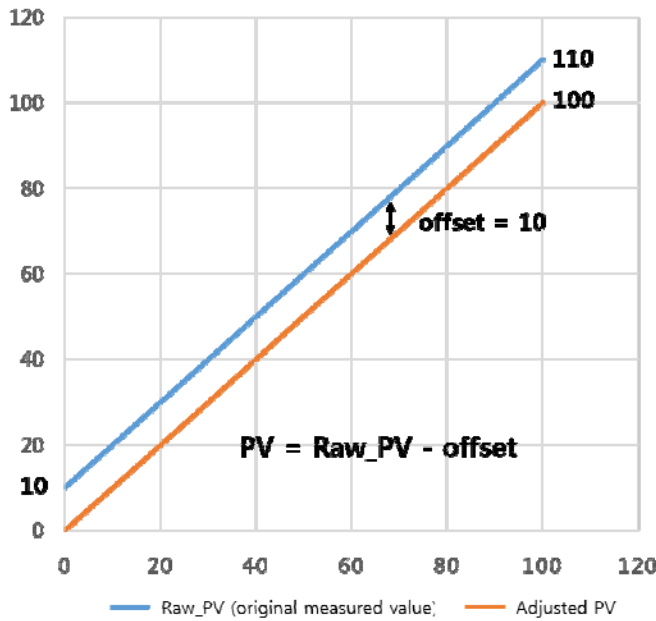

Zero Trim and Zero Adjustment are functions to control offset in the Transmitter measurement. If a constant error occurs over the whole region from low pressure to high pressure as in Figure 5-4, it is possible to eliminate measurement error by controlling offset.

In the complete vent mode with no pressure approval to Transmitter, execution of Zero Trim can eliminate offset which occurred at the zero point.

To control the currently measured value to a certain value without pressure vent, Zero Adjustment can be executed. In this case, offset is controlled to move the currently measured value to desired value. At the time of Zero Adjustment execution, the currently approved pressure should be maintained

constantly, and sufficient time should be given for the pressure approved after pressure change to be stabilized prior to execution. As for Zero offset, set-up value for user and factory initial value are stored separately, and the factory initial value can always be restored through offset factory recall function.

As for how to execute Zero Trim and Zero Adjustment making use of button, refer to Chapter 3-7. As for how to execute Zero Trim and Zero Adjustment making use of HHT, refer to each corresponding HHT manual or STT30 manual.

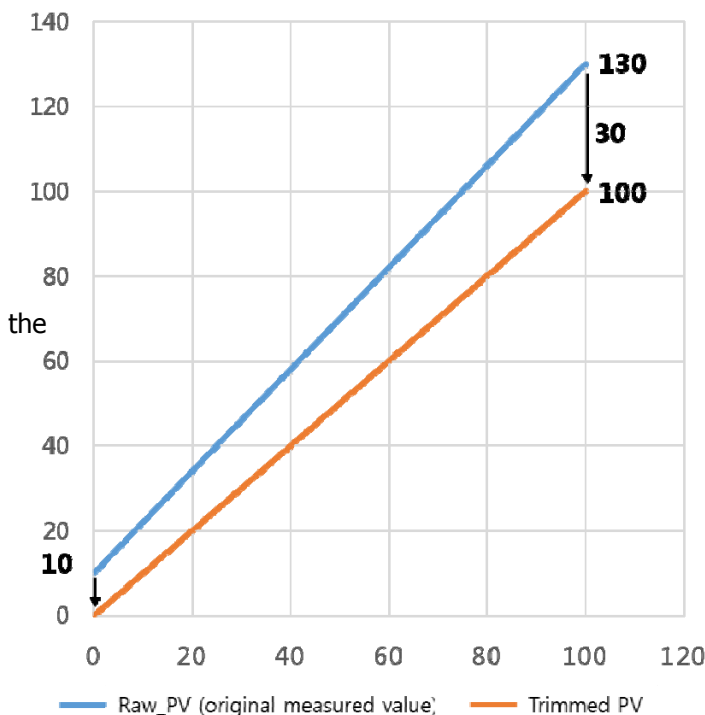

A full trim is a two-point sensor calibration where two end-point pressures are applied, and all output is linearized between them. You should always adjust the low trim value first to establish the correct offset. Adjustment of the high trim value provides a slope correction to the characterization curve based on low trim value. The factory-established characterization curve is not changed by this procedure.

The trim values allow you to optimize performance over your specified measuring range at the calibration temperature.

Simply, Zero Trim & Zero Adjustment give Offset to the

transmitter and configure them without changing the slope of characterization curve but Full trim change the slope of characterization curve after configuration.

Step for Full trimming.

(1) Set up stable pressure at 0 % of what user wants to the device during stabilization time, and then input the low trim value on 0 %.

(2) Set up stable pressure at 100% of what user wants to the device during stabilization time, and then input the high trim value on 100%.

5.9.2 DA (Digital to Analog) Trim

When the D/A trim convert sensor input signal to 4~20mA output, this output value scale minuteness. Cyclic you recommend to scale analog output for maintain scale.

This function can manage the error about analog conversion if digital value for loop current output.

Chapter 6 Maintenance

6.1 Overview

This chapter describes breakdown diagnostic and maintenance.

6.2 Safety Message

When operation, it requires specially notice for the safety of operator. Information that raises potential safety issues is indicated by a warning symbol(▲). Refer to the following safety messages before performing an operation proceeded by this symbol.

6.2.1 Warning

▲ Warning
<p>Explosion can result in death or serious injury:</p> <ul style="list-style-type: none"> ◆ Do not remove the transmitter covers in explosion environments when the circuit is alive. ◆ Both transmitter covers must be fully engaged to meet explosion-proof requirements

▲ Warning
<p>Electrical shock can result in death or serious injury. If you install high voltage environment or false condition, power line and lead will be apprered high voltages.</p> <ul style="list-style-type: none"> ◆ Avoid contact with the leads and terminals.

▲ Warning
<p>Electrical can result in death serious injury:</p> <ul style="list-style-type: none"> ◆ The qualification which is educated only the person whom it prepares will be able to establish the transmitter.

▲ Warning
<p>Process leak can result in death serious injury:</p> <ul style="list-style-type: none"> ◆ Before approval pressure install Thermowell or sensor and then close completely. If don't this, it cause process leak. ◆ when operating, don't take out Thermowell.

6.3 Hardware Diagnostics

If you suspect a malfunction despite the absence of any diagnostic messages on the HHT follow Table 6-1 described here to verify that transmitter hardware and process connections are in good working order.

If you suspect a malfunction despite the absence of any diagnostic messages on the HHT follow Table 6-1 described here to verify that transmitter hardware and process connections are in good working order.

[Table 6-1 Troubleshooting]

Symptom	Potential Source	Corrective Action
Transmitter Does not Communicate With HART Communicator	Loop Wiring	<ul style="list-style-type: none"> • Check for a minimum of 250 ohms resistance between the power supply and HHT. • Check for adequate voltage to the transmitter. The transmitter always requires 12 ~ 45 Vdc. • Check for intermittent shorts, open circuits, and multiple grounds.
High Output	Sensor Input Failure	<ul style="list-style-type: none"> • Connect HHT and enter the Transmitter test mode to isolate a sensor failure.
	Loop Wiring	<ul style="list-style-type: none"> • Check for dirty or defective terminals, interconnecting pins, or receptacles.
	Power Supply	<ul style="list-style-type: none"> • Check the output voltage of the power supply at the transmitter terminals. It should be 12 to 45 Vdc in spite of loop scale.
	Electronics Module	<ul style="list-style-type: none"> • Connect HHT and enter the Transmitter test mode to isolate module failure. Check the sensor limits to ensure calibration adjustments are within the sensor range.
Erratic Output	Loop Wiring	<ul style="list-style-type: none"> • Check the output voltage of the power supply at the transmitter terminals. It should be 12 to 45 Vdc. • Check for intermittent shorts, open circuits, and multiple grounds. • Check for proper polarity at the signal terminals. • In case measuring electric current while digital communication, output appear around $\pm 0.013\text{mA}$
	Electronics Module	<ul style="list-style-type: none"> • Connect HHT and enter the Transmitter test mode to isolate an electronics mode failure.
Low Output or No Output	Sensor Element	<ul style="list-style-type: none"> • Connect HHT and enter the Transmitter test mode to isolate a sensor failure. • Check the PV to see if it is out of range.
	Loop Wiring	<ul style="list-style-type: none"> • Check for adequate voltage to the transmitter. The transmitter always requires 12 ~ 45 Vdc. • Check for intermittent shorts, open circuits, and multiple grounds. • Check polarity of signal terminal • Check the loop impedance.
	Electronics Module	<ul style="list-style-type: none"> • Connect HHT and check the sensor limits to ensure calibration adjustments are within the sensor range.

6.4 Hardware Maintenance

Autrol APT 3500 Smart Transmitters have no moving parts and require a minimum of scheduled maintenance. Both transmitters feature modular design for easy maintenance. If you suspect a malfunction, check for an external cause before performing the diagnostics as discussed later in this section. If you must return failed transmitters or parts, send them to www.autroltransmitters.com inspection, repair, or replacement.

6.4.1 Test Terminals

The test terminal, marked as TEST on the terminal block. The test and negative terminals are connected to the test terminals; so long as the voltage across the receptacles is kept below the diode threshold voltage, no current passes through the diode. To ensure that there is no leakage current through the diode while making a test reading, or while an indicating meter is connected, the resistance of the test connection or meter should not exceed 10 ohms. A resistance value of 30 ohms will cause an error of approximately 10 percent of reading.

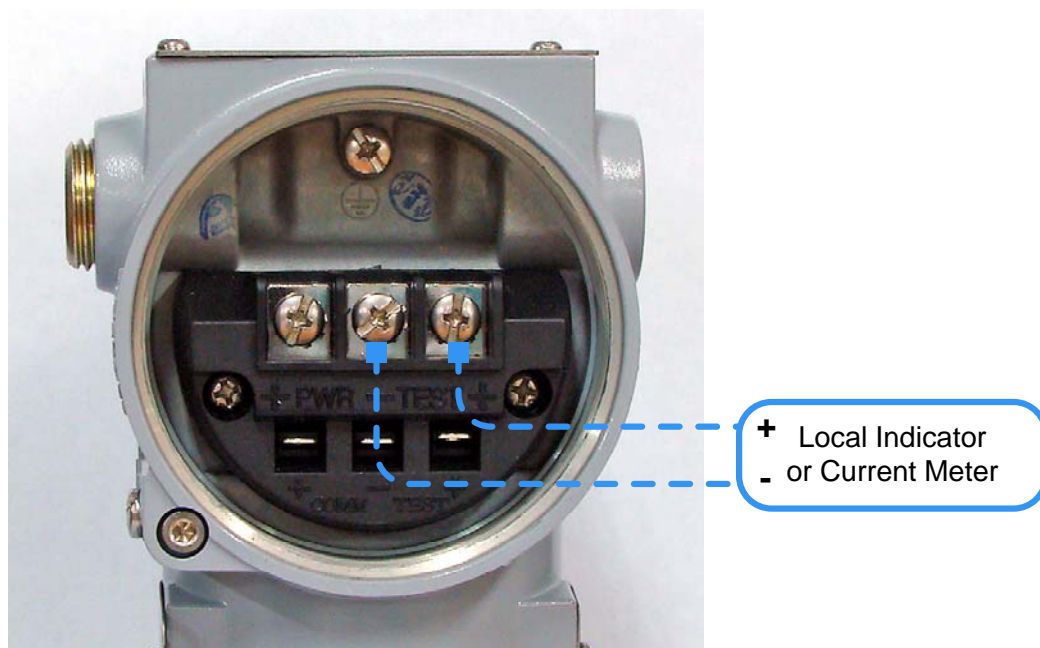

[Figure 6.1 Test Terminals]

6.4.2 Disassembling the Electronics Housing

The transmitter is designed with dual-compartment housing; one contains the electronics module, and the other contains all wiring terminals and the communication receptacles.

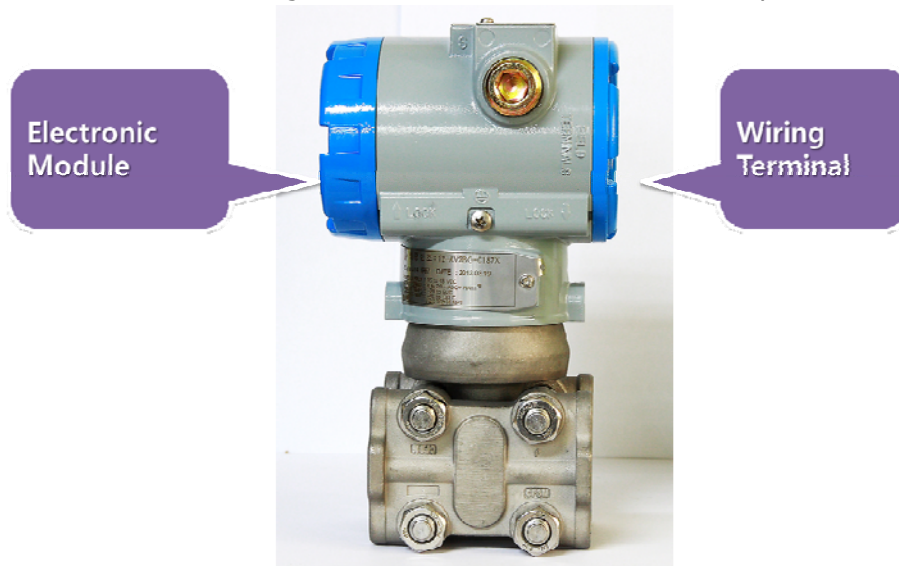

[Figure 6.2 Structure of Housing]

6.4.2.1 Disassembling Electronics Module

Use the following procedure to remove the electronics module.

[Note1]

The electronics are sealed in a moisture-proof plastic enclosure referred to as the electronics module. The module is a non-repairable unit; if a malfunction occurs the entire unit must be replaced.

1. Disconnect the power to the transmitter.
2. Remove the cover from the electronics side of the transmitter housing (Figure 6.2). Do not remove the instrument cover in explosive atmospheres when the circuit is alive. Remove the LCD meter, if applicable.
3. Remove the two screws that anchor the electronics module to the transmitter housing.
4. Firmly grasp the electronics module and pull it straight out of the housing, taking care not to damage the interconnecting pins.

[Note2]

The transmitter EEP-Write Jumpers and failure mode are located on the front of the electronics module. When it will be replaced for a new one, make a same jumper location.

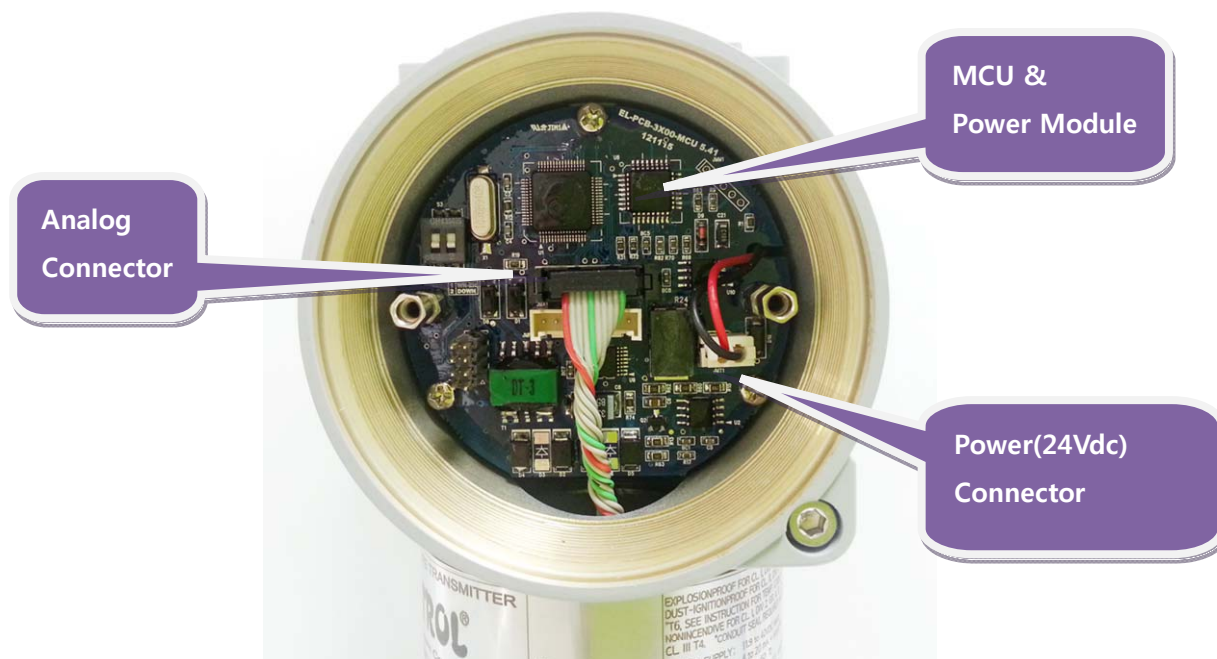

Figure 6.3 Structure of Electronics Module inner Transmitter

6.4.2.2 Fail Mode and Jumper Switch of EEPROM-write

Fail-mode and jumper switch of EEPROM-write is located front of electronics module(Refer to Figure 2-2, 2-3)

6.4.3 Assembling the Electronics Housing

Re-assembling procedure is same as follows.

1. Make sure that Fail-mode and Jumper Switch are set exactly.
2. Insert electronics module in housing
3. Firstly, connect the connector of sensor board with power connector.
 - Mis connection of the two connectors cause wrong output(4~20mA) and effect on power of Transmitter.
 - In case of power connector sandwiched between board and housing, it may cause wrong output signal and effect on power of transmitter.
4. Fix electronics module with 3 screws.
5. Close the cover of housing..

Appendix I

APT 3500 SMART PRESSURE

TRANSMITTER Message	Description	Remarks
ADJ-U	Out of Zero setting value when Zero Adj function using button(Upper side)	
ADJ-L	Out of Zero setting value when Zero Adj function using button(Lower side)	
ZERO	Initial message in using Zero button	
SPAN	Initial message in using Span button	
BT-ERR	Button input Sequence error	
P-LOCK	Button input error when Protect Locked	
ZT-ERR	Setting Limit (10%) Error when Zero Trim	
-TR-	Zero Trim Done	
ZR-ERR	Setting Limit error when executing Zero button function	
SP-ERR	Setting Limit error when executing Span button function	
-ZR-	Zero button function done	
-SP-	Span button function done	
-ZA-	Zero Adjustment done	
-DONE-	Setting Done using button	
R-OVER	Setting Limit error when executing other setting function	
LCD_OV	Over figure values for LCD	
SCD-ER	Sensor Code Error	
F-RST	Flash Setting Data Reset	
F-LOCK	While Flash Setting Data Reset, Protect Locked	
F-FAIL	Flash Setting Data Reset Failure	
-FR-	Flash Reset Done	
A-RST	Analog EEPROM Initializing Start	
A-STOR	Analog EEPROM Whole Write	
A-FAIL	Analog EEPROM Whole Write Failure	

LCD DISPLAY COD

Message	Description	Remarks
-AC-	Analog EEPROM Whole Write Done	
S-FL	Sensor Fail	
S-OP	Sensor Overpressure	
AEP-RF	Analog EEPROM read checksum error	
TS-FL	Temperature Sensor Error	
AEP-WF	Analog EEPROM write fail	
EOSC	Crystal Element Defect Alarm	
FAVE	Flash Access Violation	
PGM-ER	Program Memory CRC error	
PASSER	Wrong password input	
TOO-H	Input number is too large	
TOO-L	Input number is too small	
LCD_OV	The number to be displayed on LCD exceeds the display range	

APPENDIX II

PRODUCT CERTIFICATIONS

This Chapter describes flame-proof certification of APT 3500 series.

1. Certification Company

Company Name: Autrol (**AUTROL®**)

Region : 232, Beotkkot-ro, Geumcheon-gu, Seoul, Korea 153-801

2. KOREA (KOSHA) Flameproof

Certificate Number : 12-AV2BO-0741

Ex d IIC T6, IP67 (-20°C ≤ T_{amb} ≤ +60°C)

V_{dc} = 12.5 ~ 45Vdc, 4~20mA, Process Temperature: Below +80°C

a. KOREA (KOSHA) Flameproof Standards

Notification of Protection Device Duty of Safety Certification (Ministry of Employment & Labor Notification No. 2010-36)

3. ATEX Explosion-proof Certification

Certificate Number : xxxxxxxxxxxxxxxxxxxx

Certificate Range : Ex d IIC T6...T4, IP67

V_{dc} = 12.5 ~ 45Vdc, 4~20mA

4. Pending from FM Explosion-proof Certifier

APPENDIX III

Special Condition for Safe Use

INSTALLATION

ATEX

- ◆ **Line connection method and length should be suitable for the corresponding flameproof specification.**
- ◆ **Power approved to Transmitter should not exceed rating.**
- ◆ **To avoid problems that may occur in power connection to Transmitter, the backward diode was used. However, in the event of power connection to wrong place, the backward diode may lose its function.**

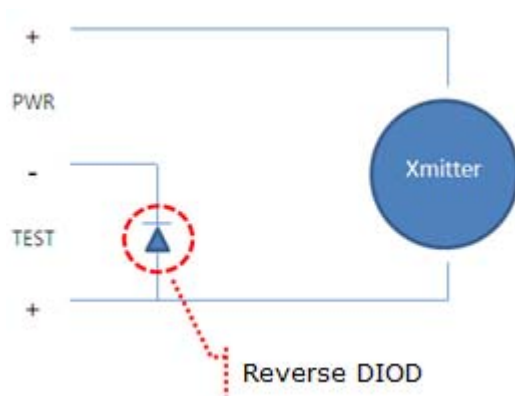

[Connection of backward diode]

- ◆ **Parts connected to Transmitter additionally should definitely obtain authorization on regional classification and gas classification.**
- ◆ **Cable entrance device should obtain certification for pressure-resistance and flameproof, and be suitable for working condition.**
- ◆ **Unused wire connection should be blocked properly with plugs.**
- ◇ **Housing ground should always follow "Local Electrical Codes". The most efficient grounding is direct connection to earth with minimal impedance.**

◇ **Housing grounding method**

- **Internal Ground Connection: Internal grounding screw is located at terminal of the housing interior, and the screw is identified by the ground symbol.**
 - **External Ground Assembly: It is located at the right side of the housing front (facing LCD), and identified by ground symbol.**
- ◇ **When impulse line is used, Stopping Boxes should be directly connected to the housing wall.**
- ◇ **Cable grand should obtain proper environment certification for flameproof to be used at ZONE 1.**
- ◇ **Impule line should engage at least five screw thread.**
- ◇ **Sensor should engage at least seven screw thread, and is prevented from rotating by tightening "Housing rotation" screw.**



TEKMATION LLC reserves the right to change the designs and/or materials of its products without notice. The contents of this publication are the property of TEKMATON and cannot be reproduced by any other party without written permission. All rights reserved. Copyright © 2016 TEKMATON LLC
DOC#TEK/MR/MN/IM-APT 3100/0119/A
TEKMATION LLC



www.autroltransmitters.com

AUTROL®, AUTROL™ are trade mark of smart transmitter brand series to measure Pressure, Temperature and Level, which is manufactured & owned by Autrol America Co., Ltd(hereafter Autrol America) since 1989. AUTROL®, AUTROL™ series also provide services of electric appliance installation, repair of electric, magnetic measuring instruments, electric appliance repair, repair of instruments and appliances for measuring and testing, repair of computer hardware, repair of electronic application machines and apparatus, repair of instruments and appliances for rotating, repair of electric power distribution machines and apparatus, repair of control machines and apparatus, computer hardware maintenance and administration, computer hardware installation. APT3500-Differential and high accuracy pressure Transmitter APT 3100-Differential pressure Transmitter, APT3200-Gauge & Absolute pressure Transmitter, APT2100-Temperature Transmitter, AI100-Field Indicator.

Autrol Corporation Of America

796 Tek Drive, Crystal Lake, IL 60014, USA

Tel: +1 847-857-6062, +1 847-779-5000 Fax: +1 847-655-6062

Email: info@autroltransmitters.com

www.autroltransmitters.com