



APT 3500

Smart Pressure Transmitter

For Differential / High Static / Gauge / Absolute Pressure Measurement



PRESSURE



APT 3500

Introduction

The APT 3500 Smart Pressure Transmitter is a micro processor-based high performance transmitter, which has flexible pressure calibration and output, automatic compensation of ambient temperature and process variable, configuration of multiple parameters, communication with HART protocol. The application is very various, as measuring liquid, gas or steam flow as well as pressure and liquid level by application method. All sensor data is input, modified and stored in EEPROM.



Function

- Flexible Sensor Input : DP, GP, AP, HS
- Various Output : 4-20mA , Digital Signals
- Setting Various Parameters : Zero/Span, Trim, Unit, Fail-mode, etc.
- Self Diagnostic Function : Sensor, Memory A/D Converter, Power, etc.
- Digital Communication with HART protocol
- Explosion-proof Approval & Intrinsic Safety Approval : ATEX, FM, FMCanada, KCs, etc.
- Marine Certificate: ABS, LR, BR, DNV



Functional Block Diagram

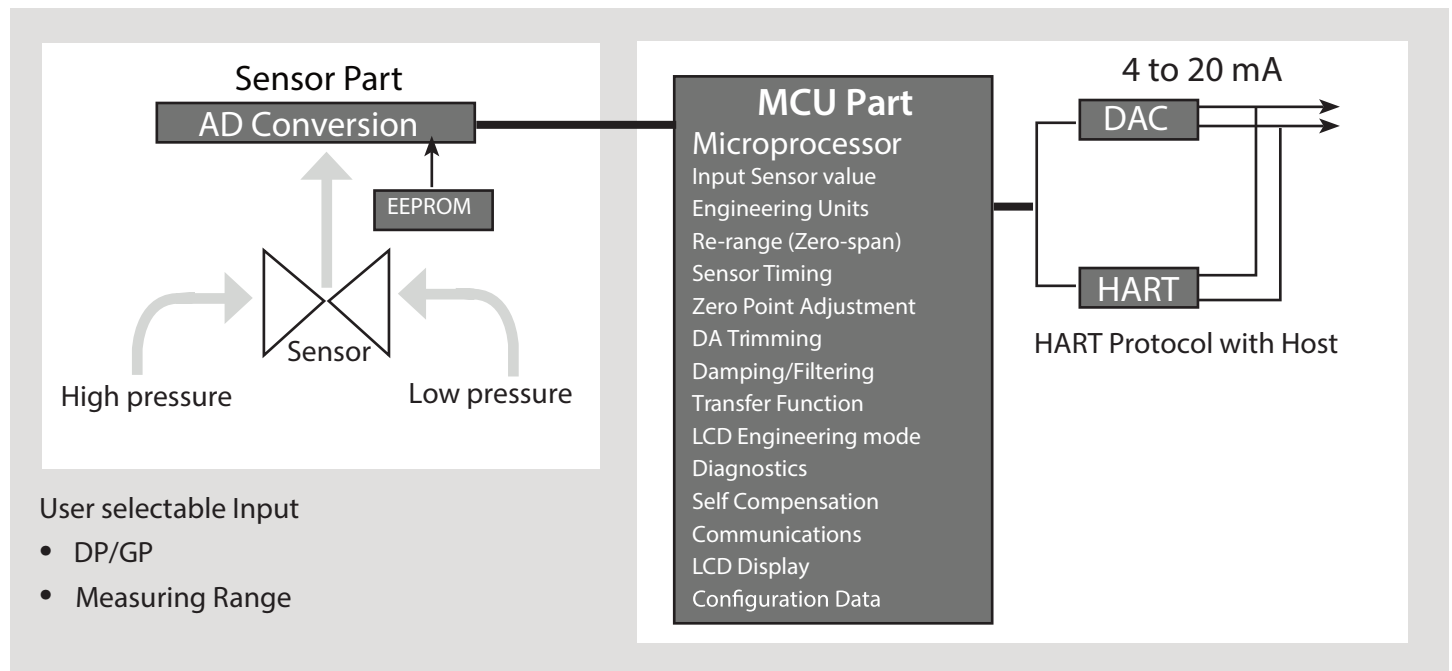

Features

Superior Performance

- High Reference Accuracy : $\pm 0.04\%$ of Calibrated Span
- Long-Term Stability (0.125% URL for 5 year)
- High Range ability (100 : 1)(for the range 3-6)

Flexibility

- Data Configuration with HART Configurator
- Zero Point Adjustment

Reliability

- Continuous Self-Diagnostic Function
- Automatic Ambient Temperature Compensation
- Fail-mode Process Function
- EEPROM Write Protection
- CE EMC Conformity Standards IEC (61000-4 Series)

Transmitter Description

ATP 3500 Pressure Transmitter can be easily configured from any host that support the HART protocol.

Basic Setup

- Operational Parameters
- 4-20mA Points (Zero/Span)
- Engineering Units
- Damping Time : 0.25-60 sec
- Tag : 8 Alphanumeric characters
- Descriptor : 16 characters
- Message : 32 characters.
- Date : day/month/year

Calibration and Trimming

- Lower/Upper Range (zero/span)
- Sensor Zero Trimming
- Zero Point Adjustment
- DAC Output Trimming
- Transfer Function
- Self-Compensation

Self-Diagnosis and Others

- CPU & Analog Module Fault Detection
- Communication Error
- Fail-mode Handling
- LCD Indication
- Temperature Measurement of Sensor Module

Specifications

Range and Sensor Limits

- Refer to Table 1.

Zero and Span Adjustment Limits

- Zero and span values can be set anywhere within the range limits stated in Table 1. Span must be greater than or equal to the minimum span stated in Table 1.

Output (Analog Current and Digital Data)

- LCD Display & ENG Mode
- Two wire 4-20mA user configurable for linear or square root output, digital process value superimposed on 4-20mA signal, available to any host that conforms to the HART protocol

EMC Conformity Standards

- IEC 61000-4 Series

Power Supply & Load Requirement

- External power supply required.
 - * 250 ohm load - 17.5 Vdc
 - * up to a 550 ohm load -24 Vdc
- Max. Loop Resistance = $(E - 12) / 0.022$
(E = Power Supply Voltage)
- Voltage Range : 12 to 45 Vdc
- Voltage Rating : 24 Vdc $\pm 30\%$
- Loop Load
 - 0-1500 ohm - Operation
 - 250-550 ohm - HART Communications

Failure Mode

- Fail High : Current ≥ 21.1 mA
- Fail Low : Current ≤ 3.78 mA

Storage Temperature

- 40°C to 85°C (-40°F to 185°F)(without condensing)

Process Temperature Limits

(Range codes and approval codes may effect limits)

- 40°C to 120°C (-104°F to 248°F)

Isolation

- Input/output isolated to 500Vrms (707 Vdc)

Working Pressure Limits (silicone oil)

- Model D & G
 - 0-5 MPa - # 1
 - 0-13 MPa - # 2
 - 0-25 MPa - # 3-6
- Model HS
 - 0-32 MPa - # 3-5
 - 0-75 MPa - # 7
- Model AP
 - 0-0.25 MPa - # 3
 - 0-1.5 MPa - # 4
 - 0-2.5 MPa - # 5

Hydrostatic Test Pressure

- Model D & G
 - 8 MPa - # 1
 - 20 MPa - # 2
 - 38 MPa - # 3-6
- Model HS
 - 48 MPa - # 3-5
 - 60 MPa - # 7
- Model AP
 - 0-0.38 MPa - # 3
 - 0-2.25 MPa - # 4
 - 0-3.75 MPa - # 5

Burst Pressure

- Model D & G
 - 69 MPa - # 1-6
- Model HS
 - 132 MPa - # 3-5
 - 80 MPa - # 7
- Model AP
 - 1.05 MPa - # 3
 - 4 MPa - # 4
 - 7 MPa - # 5

5 Digit LCD

- Express all pressure unit and flow unit
- Use 5 digit
- Select decimal place (0 to 4)
- PV, % and mA value indicate on LCD rotationally & automatically

User Define Unit Function

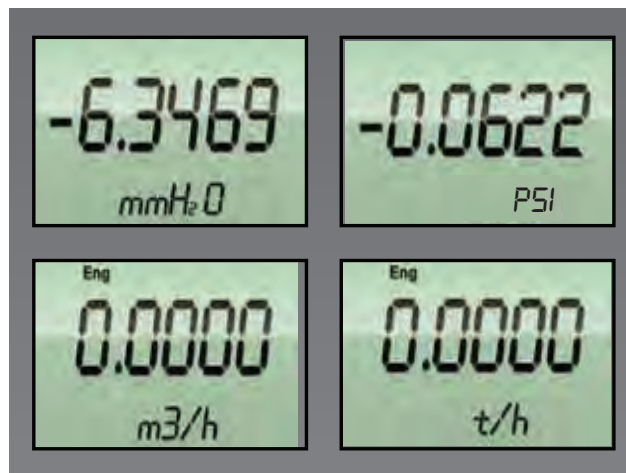

Change Main Parameter by Button

- Change Unit
- Change Upper Range Value
- Change Lower Range Value
- Change the Damping Second
- Select the Decimal Place
- Zero Trim
- Zero Adjustment



Moving within Menu : Zero
 Moving to below Menu : Span
 Moving Top Menu : Zero+Span

Physical Specifications

Wetted Materials

- Isolating Diaphragms 316L SS, Monel, Tantalum, HAST-C
- Drain/Vent Valves 316 SS, HAST-C
- Flanges and Adapters 316 SS (ASTMCF8M), HAST-C
- O-ring Viton or PTFE

Non-Wetted Materials

- Fill Fluid Silicone oil or Inert fill
- Bolts 304 SS
- Electronics Housing Aluminum or 316L SS (Optional)
Flameproof and Waterproof (IP67)
- Cover O-ring Buna-N
- Paint Epoxy-Polyester or Polyuret
- Mounting Bracket 304SS with U-bolt
- Nameplate 304SS

Electrical connections

- 1/2-14 NPT conduit with M4 Screw Terminals

Process Connections

- 1/4-18 NPT on 2.126 inch (0.17ft) centers on flanges for Standard
- 1/2-14 NPT on Process Adapter (option)
*Refer to drawing in the last page

Weight

- 3.51 kg/7.73 lb (Standard - excluding options)
5 kg/11 lb (SS Housing- excluding options)

Hazardous Location Certifications (option)

KCs Explosive-proof K1 Code

Type : Flameproof
(Ex d IIC T6, IP67 (-20°C ≤ Tamb ≤ 60°C)
Certificate No. : 12-AV2BO-0741
Power Supply : 12.5-45Vdc, 4-20mA,
Process Temperature : 80°C

ATEX Approvals E1 Code

Type : ATEX Explosion-proof Certification ATEX
Certification No. : DNV 14 ATEX 5433X
Standards : EN 60079-0 : 2012 EN 60079-1: 2007
Operating Temperature: -20°C ≤ Tamb ≤ 60°C
Ex II 2 G Ex d IIC T6...T4, IP66/67
Vcd = 12.5-45Vdc, 4-20mA

ATEX Certification E2 Code

*Intrinsic Safety: Ex ia IIC T5 or T4
Operating Temperature : For T5: -40°C to 40°C
For T4: -40°C to 70°C
Ui=30V, Ii=130mA, Pi=0.75W, Ci=40nF, Li=104μH
ATEX Certificate No.: Baseefa17ATEX0003X IECEx
Certificate No.: IECEx BAS 17.0001X

KCs Intrinsic Safety Certification K2 Code

FM and FMc Certification F1 & F2 Code

* Some certificates are on pending for approval.
Please ask us before order.

Exploded Drawing of APT 3500

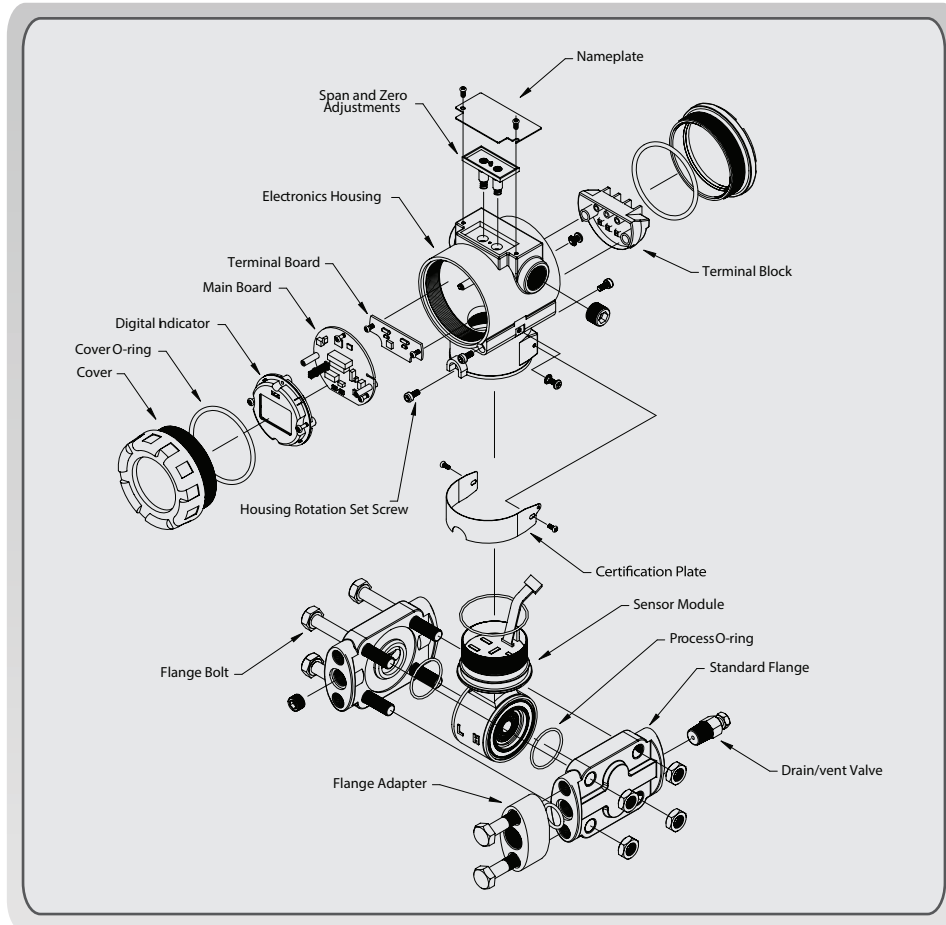

Connection Diagram of Signal, Power, HHT for Transmitter

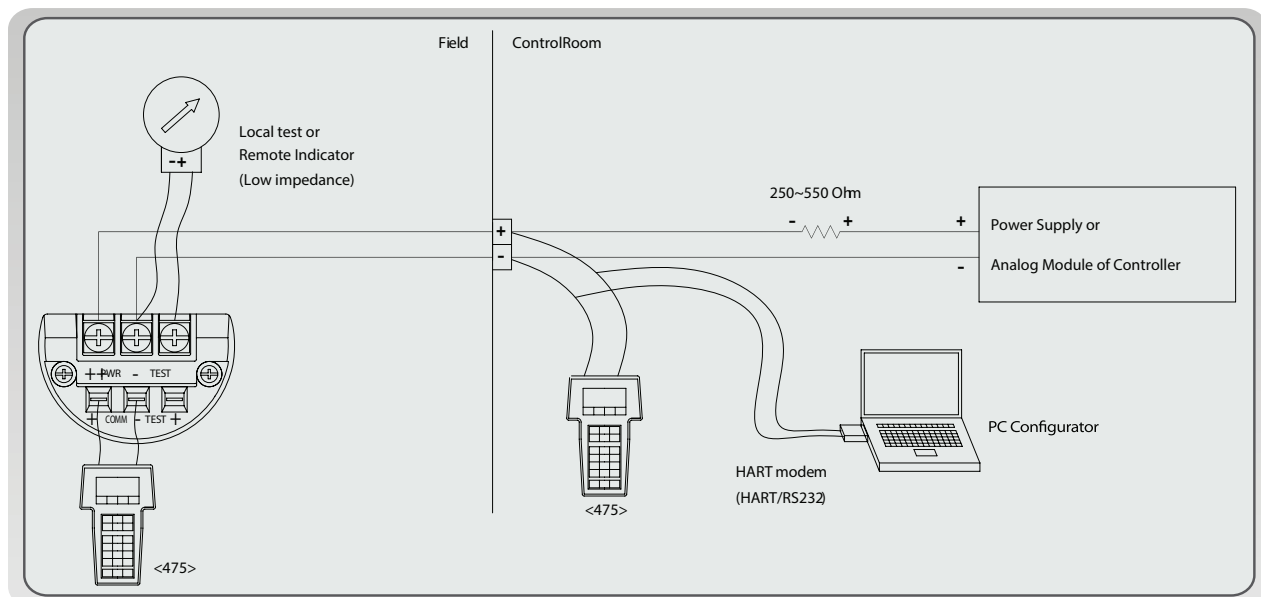

1. 475 (HART Communicator) or PC Configurator may be connected at any termination point in the signal loop.
2. HART Communication requires a loop resistance between 250 and 550 ohm @ 24 Vdc
3. Power Supply
 - Voltage Range : 12 to 45 Vdc
 - Voltage Rating : 24 Vdc \pm 30%

APT 3500

Features

- Easy Installation, Vertical Process Line
- Industrial standard connection
- Not require additional retrofitted Flanges or Adapters

Background

Traditionally, some of applications require vertical installation such as flow application, orifice assemble line, special location and etc. The traditional connections may require additional flanges or adapters, which is inconvenience and additional charge. (Except changing size of process connection).

Advantage

Direct connection from vertical process line with manifold. And it is not required additional retrofitted flanged or adapter to connect vertical process line or assemble manifold because it has industrial standard size 54 mm between L & H process connection in the transmitter. Moreover, Manifold can be connected directly.

Dimension

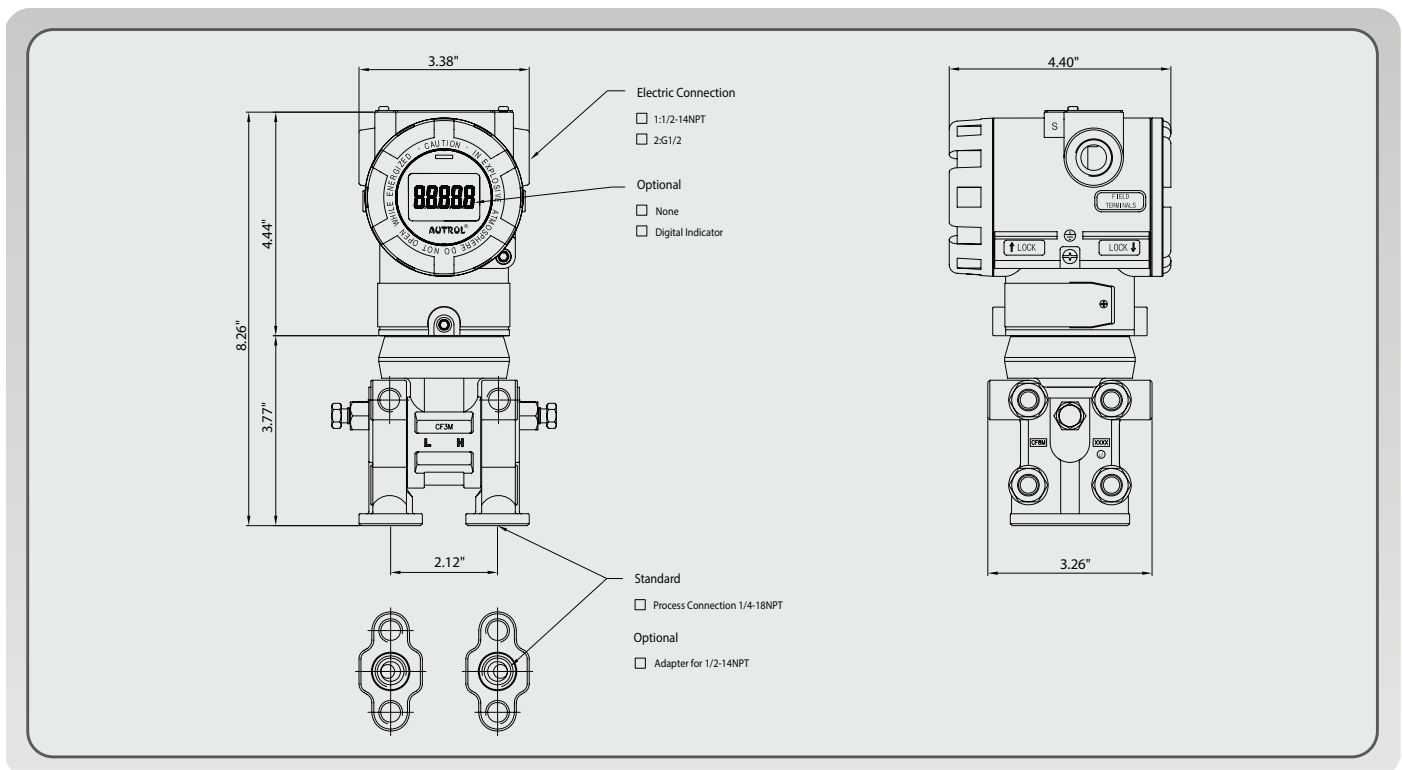

General Specification

(Rangeability : #1=20:1 / #2=50:1 / 4-6=100:1)

1. APT 3500 Pressure Sensor Range

Range Code	DP		GP		AP		HS	
	Calibrated Span (psi)	Lower Range (KPa)	Calibrated Span (KPa)	Lower Range (KPa)	Calibrated Span (KPa)	Lower Range (KPa)	Calibrated Span (KPa)	Lower Range (KPa)
1	0.009-0.181	-1.25	0.0625-1.25	-1.25				
2	0.02-1.087	-7.5	0.15-7.5	-7.5				
3	0.09-9.427	-65	0.65-65	-65	2.5-250	0	0.65- 65	-65
4	0.36-36.259	-250	2.5-250	-100	15-1500	0	2.5-250	-250
5	3.04-305	-2100	21-2100	-100	25-2500	0	21-2100	-2100
6	20-2031	-14000	140-14000	-100				
7							00-40000 (Gauge Only)	0

Range Code	KPa	Kgf/cm ²	bar	psi	inH ₂ O@4°C	mmH ₂ O@4°C	inHg@0°C
1	1.25	0.012	0.0125	0.181	5.018	127.464	0.369
2	7.5	0.076	0.075	1.087	30.11	764.787	2.214
3	65	0.662	0.65	9.427	260.958	6628.154	19.194
4	250	2.549	2.5	36.259	1003.685	25492.9	73.825
5	2100	21.414	21	304.579	8430.958	214140.359	620.129
6	14000	142.76	140	2030.527	56206.38	1427602	4134.197

2. Electrical Specifications

Power Supply	12 to 45 Vdc
HART Loop Resistance	250-550 ohm
Output Signal	4-20 mA dc / HART
Isolation	500 Vrms (707 Vdc)

3. Performance Specifications

Reference Accuracy	± 0.04% of Span *See the specification feature	
Ambient Temp. Effect	Range 1 (DP & GP)	±[0.2% URL+0.08% Span] / 28°C
	Range 2 (DP & GP)	±[0.13% URL+0.12% Span] / 28°C
	Range 3-6 (DP,GP,HS)	±[0.024% URL+0.045% Span] / 28°C
	HS7, AP3-5	±[0.019% URL+0.125% Span]
Stability	±0.125% URL for 60 Months	
Ambient Temperature	-40°C - 85°C (-40°F - 185°F)	
LCD Meter Ambient Temp.	-30°C - 80°C (-22°F - 176°F)	
Humidity Limits	5%-100% RH	
Process Temperature Limits	-40°C - 120°C (-40°F - 248°F)	
Power Supply Effects	±0.005% of Span per Volt	
Mounting Position Effects	Zero Shift up to 400Pa No Span Effect	

Position Effect (90°)		Zero Shift up to ± 0.4 KPa	
Static Pressure Effect	Zero	Range 1	±0.12% of URL per 0.7MPa
		Range 2	±0.25% of URL per 7MPa
		Range 3-6	±0.05% of URL per 7MPa
	Span	Range 1	±0.15% of reading per 0.7MPa
		Range 2	±0.4% of reading per 7MPa
		Range 3-6	±0.1% of reading per 7MPa

4. Physical Specifications

Isolating Diaphragm	316L SS
Drain & Vent Valve	316L SS
Flange & Adapter	316L SS
O-ring	Viton or PTFE
Electronic Housing	Aluminum (Option: 316L SS)
Bolts & Bolting Flange	304 SS
Process Connection Size	1/4 - 18 NPT
Adapter – Option	1/2 – 14 NPT
Electrical Connections	1/2 – 14 NPT
Weight (Excluding Option Items)	3.51Kg/7.73 lb (Standard) 5 Kg/11 lb (SS Housing)
2" Pipe Stanchion Type bracket	Angle or Flat type
Housing Class	Waterproof (IP67), 4X

Installation With Mounting Bracket

2" Pipe Mounting Bracket Model Angle Type

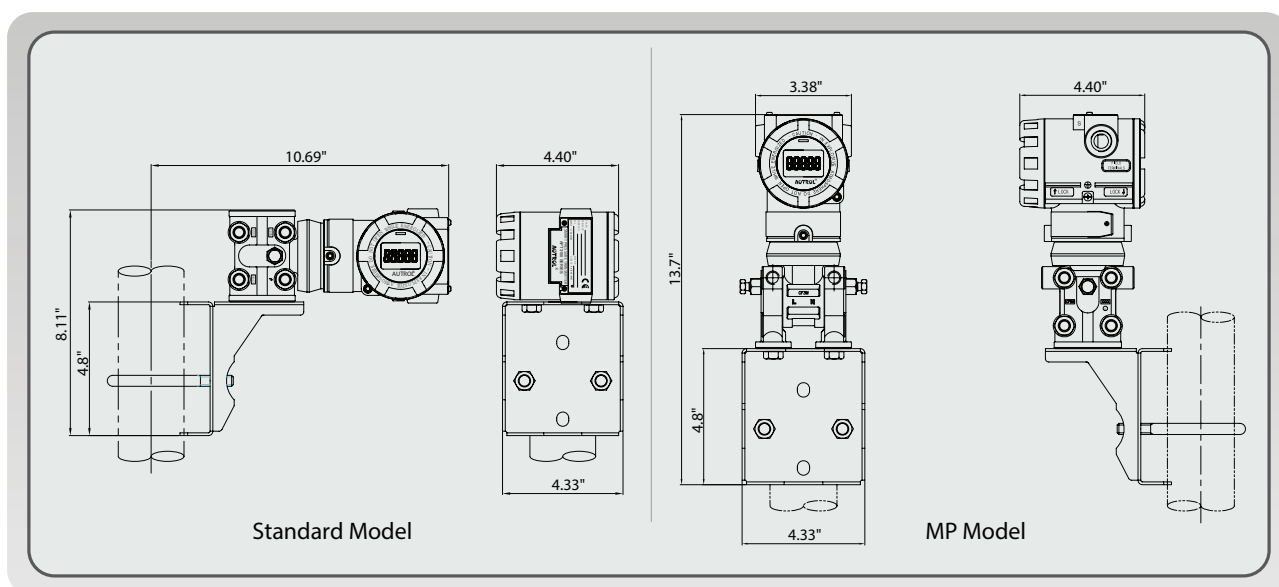

2" Pipe Mounting Bracket Model Flat Type

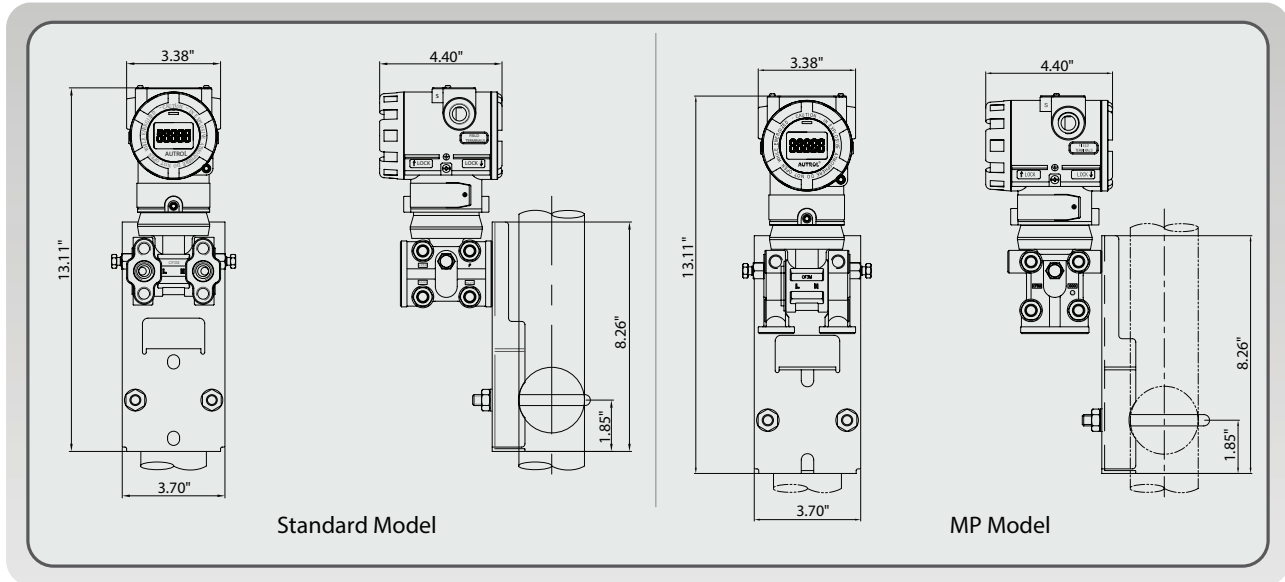

Dimensions of Transmitter Standard Model

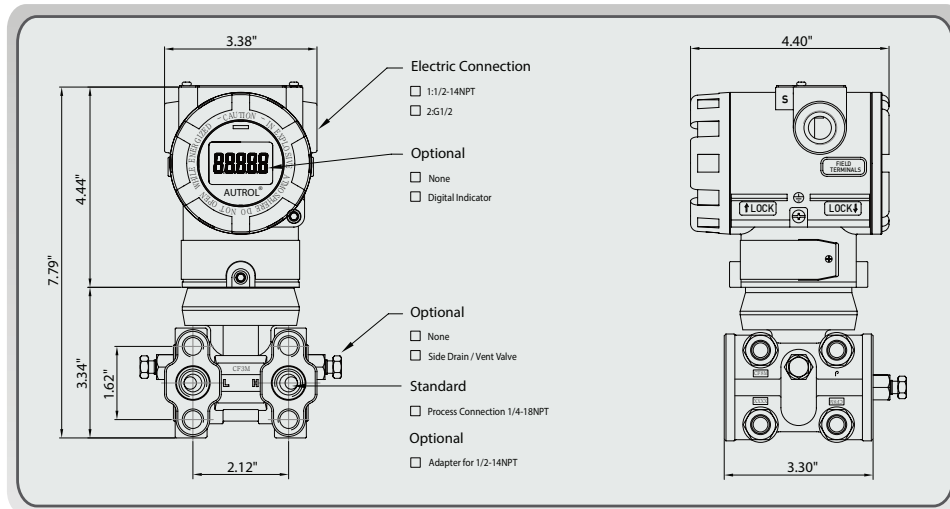

High Static Pressure Model

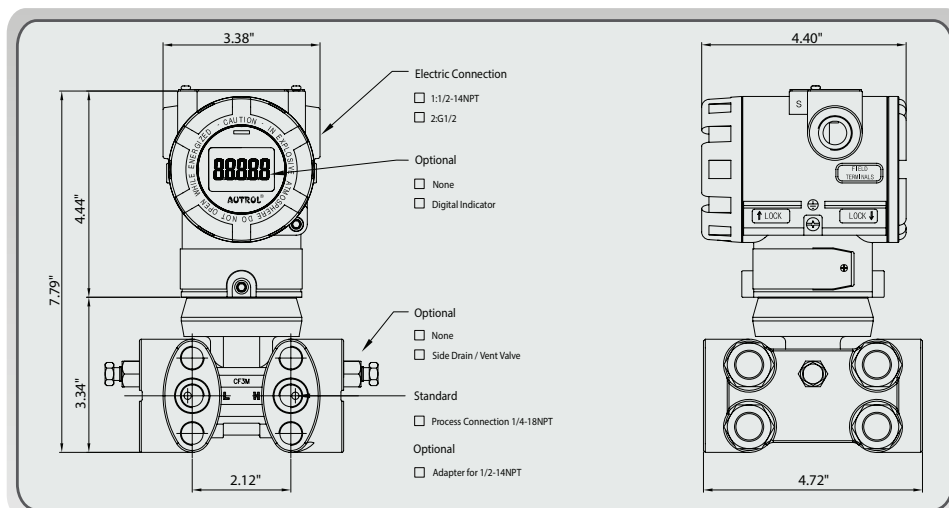

Intrinsically Safe Model

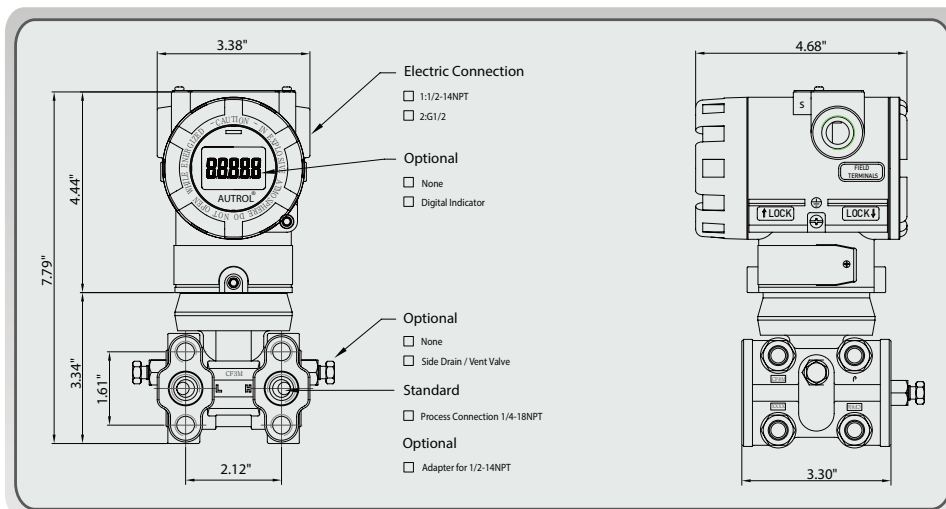

Model Chart

MODEL	Code	Description								
APT 3500/APT3500N (Nuclear)	-D	Differential Pressure Transmitter (Static Pressure 25MPa/3626 psi)								
	-HS	Differential Pressure Transmitter for High Line Pressure (Static Pressure 32MPa/4641 psi)								
	-G	Gauge Pressure Transmitter								
	-A	Absolute Pressure Transmitter								
Ranges		DP		GP		AP		HS		
		Calibrated Span (KPa)	Lower Range (KPa)	Calibrated Span (KPa)	Lower Range (KPa)	Calibrated Span (KPa)	Lower Range (KPa)	Calibrated Span (KPa)	Lower Range (KPa)	
	1	0.009-0.181	-1.25	0.0625-1.25	-1.25					
	2	0.02-1.087	-7.5	0.15-7.5	-7.5					
	3	0.09-9.427	-65	0.65 - 65	-65	2.5-250	0	0.65- 65	-65	
	4	0.36-36.259	-250	2.5-250	-100	15-1500	0	2.5-250	-250	
	5	3.04-305	-2100	21-2100	-100	25 -2500	0	21-2100	-2100	
	6	20-2031	-14000	140-14000	-100					
7							400-40000 (Gauge Only)	0		
X	Special									
Mounting Flange/ Material		Body		Flange & Adapter		Vent Plug		Diaphragm		
	M11	316 SS		316 SS		316 SS		316L SS		
	M12	316 SS		316 SS		316 SS		HAST - C		
	M13	316 SS		316 SS		316 SS		Monel		
	M14	316 SS		316 SS		316 SS		Tantalum		
	*M21	316 SS		HAST - C		HAST - C		HAST - C		
	*M22	316 SS		HAST - C		HAST - C		Monel		
*M23	316 SS		HAST - C		HAST - C		Tantalum			
Hazardous Location Certifications	K0	Maker Standard (Waterproof: IP67)								
	K1	KCS Flameproof Approval				*K2	KCS Intrinsic Safety Approval			
	E1	ATEX (KEMA) Flameproof				*E2	ATEX (KEMA) Intrinsic Safety			
	*I1	IECEx Flameproof				*I2	IECEx Intrinsic safety			
	*F1	FM & FM Canada Explosion proof				*F2	FM & FM Canada Intrinsic Safety			

MODEL	Code	Description				
Fill Fluid	1	Silicone (DC200)	2	Inert fill fluid (Halocarbon oil)		
Process Connection	S	1/4 - 18 NPT (Standard)	O	1/2-14 NPT Female (Adapter)	X	Special
Electrical Connection	1	1/2-14NPT Epoxy-Polyester Painted Aluminum	2	G1/2-14 Epoxy- Polyester Painted Aluminum (Adapter)	X	Special
Option	M1	LCD Indicator (5digit)				
	BC	Bottom Process Connection				
	LPI	Lightning Protector (Internal)	LPE	Lightning Protector (External)		
	K	Oil Free Finish				
	F1	Side Vent / Drain Top				
	F2	Side Vent / Drain Bottom				
	2W	2 Way Manifold (SS) : Remote type	2WF	Flange type		
	3W	3 Way Manifold (SS) : Remote type	3WF	Flange type		
	5W	5 Way Manifold (SS) : Remote type	5WF	Flange type		
	BA	Stainless Steel Bracket (Angle type) with SS Bolts				
	BF	Stainless Steel Bracket (Flat type) with SS Bolts				
	ST	Stainless Steel Housing				
	T	Teflon O-Ring (Wetted Part)				
X	Special					

Example: APT 3500-D5-M11-E1-1-S-1-M1-BA

Note 1: Request to manufacturer for Draft Range, Absolute (small pressure and vacuum) and Items marked " * " before order.

Customer Service and Support



TERKAMATION LLC reserves the right to change the designs and/or materials of its products without notice. The contents of this publication are the property of TERKAMATION and cannot be reproduced by any other party without written permission. All rights reserved. Copyright © 2016 TERKAMATION LLC
DOC # AUTROL/MR/190109/APT 3500/A
TERKAMATION LLC



www.autroltransmitters.com

AUTROL®, AUTROL™ are trade mark of smart transmitter brand series to measure Pressure, Temperature and Level, which is manufactured & owned by Autrol America Co., Ltd (hereafter Autrol since 1989. AUTROL®, AUTROL™ series also provide services of electric appliance installation, repair of electric, magnetic measuring instruments, electric appliance repair, repair of instruments and appliances for measuring and testing, repair of computer hardware, repair of electronic application machines and apparatus, repair of instruments and appliances for rotating, repair of electric power distribution machines and apparatus, repair of control machines and apparatus, computer hardware maintenance and administration, computer hardware installation. APT 3500-Differential and high accuracy pressure Transmitter APT3100-Differential pressure Transmitter, APT 3200-Gauge & Absolute pressure Transmitter, APT2100-Temperature Transmitter, AI100-Field Indicator.

Autrol Corporation Of America

796 Tek Drive, Crystal Lake, IL 60014, USA

Tel: +1 847-857-6062, +1 847-779-5000 Fax: +1 847-655-6062

Email: info@autroltransmitters.com

www.autroltransmitters.com